

www.costeffectiveequipment.com

+1-573-466-4300

Owner's Manual

Apogee™ Developer



Cost Effective Equipment

Contents

1. Apogee™ Developer Introduction	4
1.1. Confidentiality Statement	4
1.2. Warranty	4
1.3. Returned Materials.....	4
1.4. Model and Revisions.....	5
1.5. Safety Hazards/Precautions.....	5
1.6. Overview of Equipment-Specific Hazards.....	5
1.7. Electrical.....	5
1.8. Mechanical	5
1.9. Chemical.....	6
1.10. Lockout/Tagout Procedures and Information	6
1.11. Intended Use of Machine.....	6
2. Equipment Description	7
2.1. Dimensions.....	8
2.2. Programmability.....	8
2.3. Precision.....	8
2.4. Reliability.....	8
2.5. Bowl Design.....	8
2.6. Utilities	9
3. Installation	9
3.1. Floor Space Requirements	9
3.2. Facilities Requirements.....	10
3.3. Environment	11
3.4. Unpacking/Inspection	11
3.5. System Installation and Setup.....	11
3.6. Start Up.....	12
4. Developer Use and Operation	13
4.1. Spin Chuck.....	13
4.2. 5- Hole Dispense Nozzle Hub.....	13
4.3. Lid Adjustment.....	13
5. Preventative Maintenance	14
5.1. Safety Checks	14
5.2. Mechanical Checklist	14
5.3. Utility Checks	14

5.4. Cleaning..... 15

1. Apogee™ Developer Introduction

1.1. Confidentiality Statement

Information supplied is for the use in the operation and/or maintenance of Cee equipment. Neither this document nor the information it contains shall be disclosed to others for manufacturing or any other purpose without written authorization from, Cost Effective Equipment, LLC.

1.2. Warranty

Cost Effective Equipment, LLC warrants to the original purchaser (Buyer) that equipment is free from defects in material and workmanship under normal use and service in accordance with Cee instructions and specifications. Buyer shall promptly notify Cee of any claim against this warranty, and any item to be returned to Cee shall be sent with transportation charges prepaid by Buyer, clearly marked with a Return Authorization (RMA) number obtained from Cee Customer Support. Cee's obligation under this warranty is limited to the repair or replacement, at Cee option, of any equipment, component or part which is determined by Cee to be defective in material or workmanship. This obligation shall expire one (1) year after the initial shipment of the equipment from Cee.

This warranty shall be void if:

- (a) Any failure is due to the misuse, neglect, improper installation of, or accident to the equipment.
- (b) Any major repairs or alterations are made to equipment by anyone other than a duly authorized representative of Cee. Representatives of Buyer will be authorized to make repairs to the equipment without voiding warranty, on completion of the Cee training program.
- (c) Replacement parts are used other than those made or recommended by Cee.

CEE MAKES NO OTHER WARRANTIES, EXPRESSED OR IMPLIED, WITH RESPECT TO EQUIPMENT. NO WARRANTY IS MADE AS TO THE MERCHANTABILITY OF THE EQUIPMENT NOR ITS FITNESS FOR ANY PARTICULAR PURPOSE. In no event shall Cee be liable for consequential loss or damages, however caused. No person or representative of Cee is authorized to assume for Cee any liability in connection with Equipment nor to make any change to this warranty unless such change or modification is put in writing and approved by an authorized representative of Cee in writing.

This warranty shall be governed by the laws of the state of Missouri U.S.A.

1.3. Returned Materials

Any materials, parts, or equipment returned Cost Effective Equipment, LLC must be clearly labeled with a Return Material Authorization (RMA) number.

To obtain a RMA number, contact:

Cee Customer Support
Telephone: (573) 466-4300
E-Mail: support@costeffectiveequipment.com
Web Address: <http://www.costeffectiveequipment.com>
Shipping information with RMA number:

Attn: Cee Customer Support
Cost Effective Equipment
3703 HyPoint Blvd
Rolla, Missouri 65401

1.4. Model and Revisions

The model and serial number information for the Cee® Apogee™ are located on the rear panel near the power inlet. Software version information can be found on the About screen. See DataStream™ Manual for screen shots and a detailed explanation of the system software.

1.5. Safety Hazards/Precautions



Read this manual in its entirety before operating the machine.

1.6. Overview of Equipment-Specific Hazards

The unit is very heavy and proper precautions should be taken when handling the machine to minimize risk of injury. Labels are placed on the machine to identify areas where caution is needed during operation.

1.7. Electrical



High voltage is present in the machine. Disconnect the power before servicing.



Stored electrical energy is present in the machine. Before servicing allow sufficient time for discharge. The servo amp has a charge light; do not service the machine until this light has gone out.

1.8. Mechanical



This machine uses compressed gasses, which can provide motive force for components and can expand violently upon decompression. Disconnect N2 or CDA before removing any panels.



The machine is capable of very high-speed rotation. Ensure all lids and panels are in place before rotating these devices.



Ensure that all panels are on and in their correct locations before powering up or operating.











When opening the lid be aware of the pinch point at the hinge cover. Open the lid only by using the handle on the lid.



The unit is very heavy and proper precautions should be taken when handling or moving the machine to minimize risk of injury.

1.9. Chemical

-  Ensure chemical compatibility of all chemicals and materials being used inside the machine. This includes all wetted parts of the storage, supply, dispense, and waste systems.
-  Ensure chemical compatibility of all chemicals with each other. All dispensed materials are held in one common waste storage tank. Check for reactions between chemicals before use.
-  Flammable Chemicals. No open flames/sparks.
-  Relieve pressure before opening canisters, tanks, cartridges, or syringes to refill.
-  Relieve pressure and shut off chemical valves before servicing supply lines, dispense valves or other components.
-  Relieve pressure and shut off chemical valves before removing spin lid or changing BSR tubes, EBR tubes, or any other dispense nozzle or spray tip.
-  Flush tubing and valves with an appropriate solvent and drain system before servicing. When draining waste tank, use appropriate containers and connection methods.
-  Ensure proper ventilation/exhaust is used at all times.
-  Always wear the proper Personal Protective Equipment for the job. This includes safety glasses, gloves and other equipment as needed to protect from mechanical and chemical hazards.

1.10. Lockout/Tagout Procedures and Information

Before servicing, turn off the machine and remove the power inlet cord by disconnecting the plug where it enters the machine.

1.11. Intended Use of Machine

The Cee® Apogee™ Developer is intended for use as a Semiconductor/Optical application spin coating machine. It is primarily intended for substrates up to the maximum size.

The Cee® Apogee™ Developer is not intended for use in food or medical applications or for use in hazardous locations.

The Cee® Apogee™ Developer is intended for use only by properly trained personnel wearing the proper personal protective equipment. Anyone not trained in the proper use of the Apogee™ Developer and have not fully read this manual should not operate the equipment.

The Cee® Apogee™ Developer is intended for use in a cleanroom environment to provide the proper processing conditions for the substrates. If it is used outside of a cleanroom environment, the substrate cleanliness may be compromised.

The Cee® Apogee™ Developer is not intended for use in a hazardous or explosive environment.

2. Equipment Description

The Cee® Apogee™ Developer delivers track-quality performance, with revolutionary interface capabilities and the utmost in chemical compatibility, in an efficient, space-saving design.

Fully programmable and user-friendly, the Cee® Apogee™ Developer features the accuracy and repeatability needed to eliminate processing variability from critical experiments. With its convenient compact footprint, wide array of chemical compatibility, and durability, this easy-to-use benchtop system will provide years of high-performance operation, making the Cee® Apogee™ Developer purchase a smart and cost-effective decision.

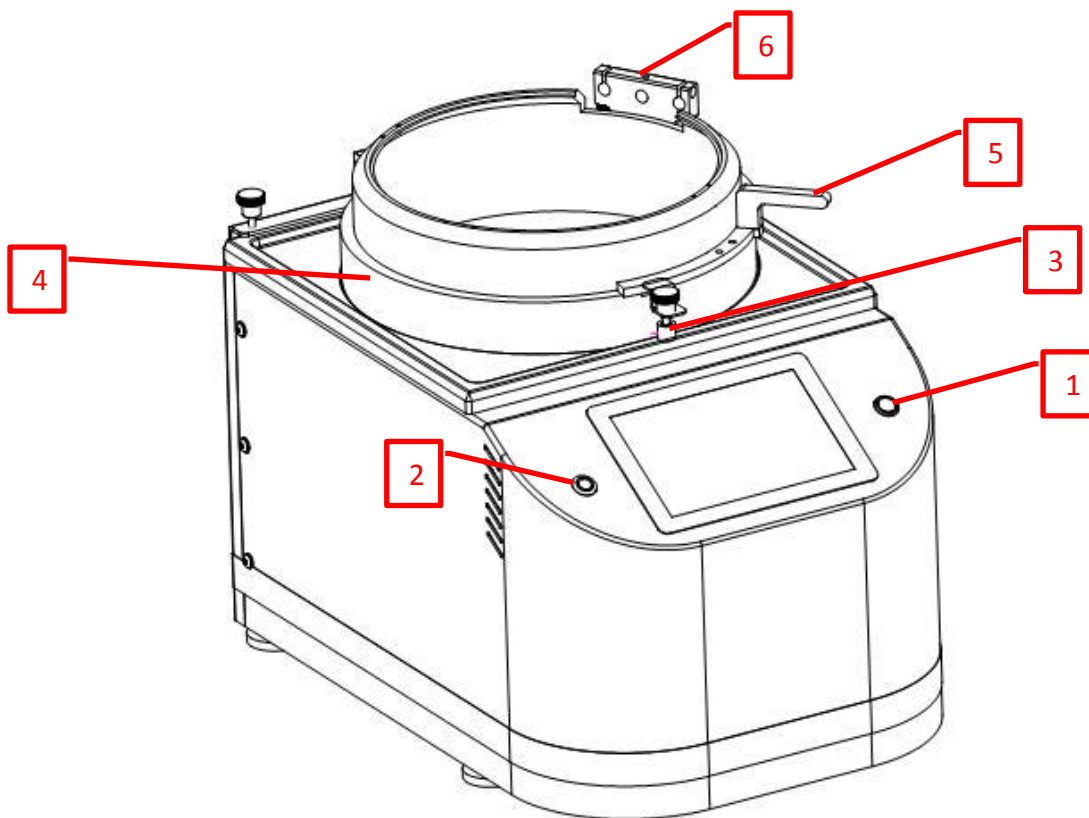

1. **Power Button** – Used to turn on and off the tool
2. **User Presence Button** – Used for remote access (see DataStream™ Manual)
3. **Lid Sensor** – Detects when the lid is closed
4. **Developer Lid** – Cover for the spin bowl (optional chimney hood available)
5. **Lid Handle** – Used to open and close the lid
6. **Dispense Bracket** – Used to hold dispense nozzles

2.1. Dimensions

- 13.25" (33.65 cm) W × 19" (48.26 cm) D × 12" (30.48 cm) H
- Machine weight: 40 lb (18.14 kg)
- Shipping weight: 100 lb (45.36 kg)

2.2. Programmability

- Touch screen interface and display
- Full-color alphanumeric-capable graphical user interface (GUI)
- A virtually unlimited number of user-defined recipe program steps
- 0.1-second resolution for step times (9,999.9 seconds maximum step time)
- Spin speed: 0 to 6,000 rpm (12,000 rpm option at no charge)
- Spin speed acceleration: 0 to 30,000 rpm/s unloaded 0 to 23,000 rpm/s with a 200-mm substrate 0 to 3,000 rpm/s with a 6" × 6" × 0.250" photomask in a recessed chuck
- Connectivity: USB/Ethernet port for communications for uploading/downloading process parameters with DataStream™ technology
- Simultaneous dual automated dispense capability
- In-process/dynamic speed/acceleration control

2.3. Precision

- Spin speed repeatability: < 0.2 rpm
- Spin speed resolution: < 0.2 rpm
- Substrate sizes: < 1 cm to 200 mm round; 7" x 7" square

2.4. Reliability

- Indirect drive system protects the spin motor from contact with process chemicals and solvents
- Vacuum and lid interlock
- Industry-leading reliability and uptime
- 1-year full warranty on parts and labor
- Free remote technical support (phone, email, fax) for the life of the product
- Application process assistance for life of the product

2.5. Bowl Design

- High-density polyethylene (HDPE) spin bowl for material compatibility
- Optional stainless or Teflon® bowl
- Optional polyethylene disposable liners available
- Versatile lid design allows process flexibility and repeatability
- Optional nitrogen purge for an inert spin environment
- Integrated drain and exhaust ports

2.6. Utilities

- Voltage ranges: 100-125, 208-240 VAC, 50/60 Hz
- Power requirements: 655 watts
- Drain port: ¾" OD
- Exhaust port: 1" OD
- Vacuum: 20 to 25" Hg
- Exhaust: 20 to 50 cfm at 0.2" water
- Nitrogen or CDA (for automated dispense): 70 psi

3. Installation

3.1. Floor Space Requirements

The Apogee™ Developer is a bench top unit and requires a table or bench top for location. In most cases the supporting structure will be larger than the unit itself. The recommended freestanding space requirements are: 1'0" back to front and 0'3" side to side.

Dimensions: 13.25"L x 19"D x 12"H

Weight: 120 lbs

3.2. Facilities Requirements

The Apogee™ Developer requires the following utilities for operation. Locations for connections are shown in the figure below.

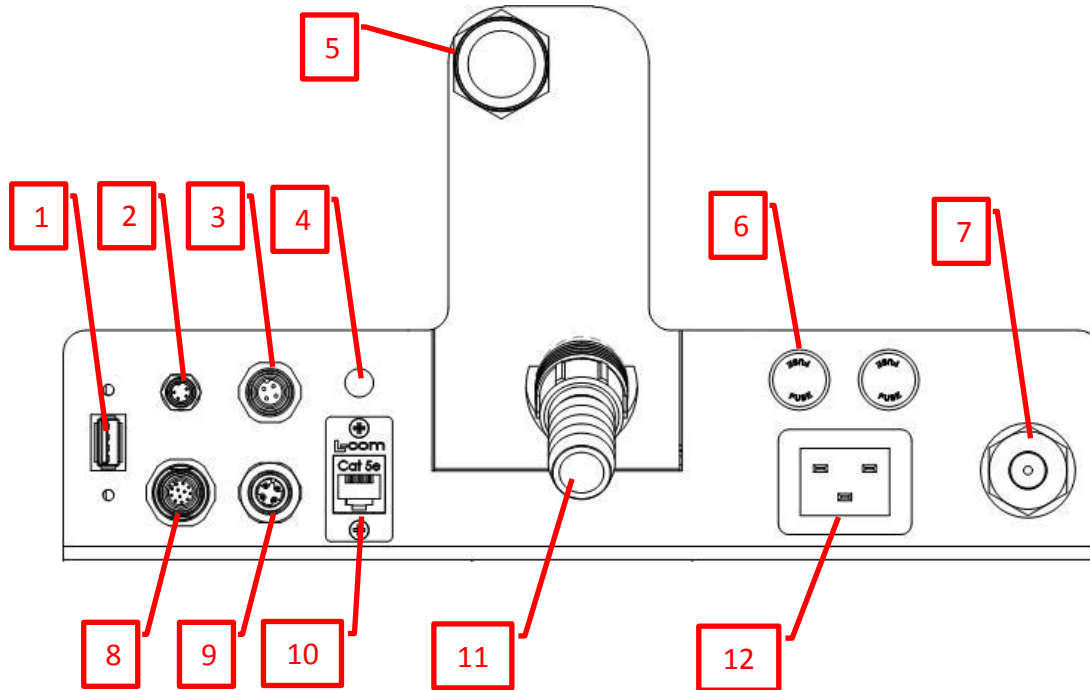

1. **USB Port** – Used to update the software or download log files (see DataStream™ Manual)
2. **Programmable Exhaust (Optional)** – Communication port for optional Programmable Exhaust module
3. **Light Tree (Optional)** – Port for optional light tree
4. **Backside Rinse (BSR) (Optional)** – Fitting for dispense material for optional Backside Rinse
5. **Spin Bowl Exhaust Port** – Exhaust port for spin bowl vapors. Port is 1 Inch OD and 50 CFM of exhaust is recommended
6. **Fuses** – System protection fuses
7. **System Vacuum** – System vacuum for vacuum chuck. Recommended vacuum Supply is 20 in Hg at a flow of 5 l/min. Port is ¼” barb fitting
8. **Dispense Trigger** – This port is used to connect to the optional dispense control box. This is used when using automated dispenses
9. **Accessory Port** – This is used to talk to external I/O device to support extra outputs and inputs.
10. **Ethernet** – The ethernet can be used for remote recipe writing and remote control (see DataStream™ Manual)
11. **Spin Bowl Drain** – The port that removes the liquid waste from the machine. The port is ¾” OD.
12. **AC Power In** – Cord is Provided. Single Phase 100-120V AC at 10 Amps (208-240V A/C option available, see back label shown in Figure 1 to verify)

3.3. Environment

The Apogee™ Developer should be operated in a clean, low humidity environment.

3.4. Unpacking/Inspection

Thoroughly check machine for shipping damage. If physical damage is seen, **DO NOT APPLY POWER!** Contact Cee™ immediately.

The following items should be included with the shipment.

- (1) Apogee™ Spin Developer
- (1) Temperature and Humidity Sensor
- (1) Power Cord with female power connector
- (1) User & Installation Manual – CD or USB

Optionally included items:

- Spin Chucks with Screws
- Dispense Controllers
- Dispense Valves
- Dispense Nozzles
- Dispense Hubs

3.5. System Installation and Setup

1. Lift the unit out of the packing crate by grasping the bottom only. **Do not** lift the by any of the top covers or protrusions. **Do not** roll or turn the unit on its side or ends.
2. Remove plastic wrap and packing foam.
3. Place Cee™ Apogee™ Developer on a table of proper height and strength so that the controls and spin chuck are at the proper ergonomic height.
4. Level the machine using the feet so that the spin chuck is level front-to-back and side-to-side.
5. Thoroughly clean the spin bowl and spin chuck.
6. Connect utilities to the reference diagram in Section 3.7.2
 - (1) Connect the temperature/humidity sensor to the CAN terminal (#9).
 - (2) Connect the vacuum supply to the vacuum fitting (#7)
 - (3) Connect the drain to the drain port (#11)
 - (4) Connect the exhaust lines to the exhaust port (#5)
 - (5) Connect the optional dispense box is equipped to the dispense triggers (#8)
7. Connect any dispense as indicated on the separate dispense diagrams.
8. Plug in the machine.
9. Once plugged in, only the cooling fan should be powered, not the display.

3.6. Start Up

***For detailed software information, please refer to the DataStream™ manual**

1. Install the tool as shown earlier in Section 4.
2. Press the lighted power switch to turn the tool power on.
3. The display should momentarily show boot screen and then show main screen.
4. Enter the username and password.
 - (1) The default username and password are “admin” and “admin2” respectively.
5. The tool will login and display the Process page.
6. Navigate to Tools- Manual Control to run system checks to ensure the tool is working properly.
 - (1) Turn vacuum on. Use your gloved hand to ensure vacuum is coming through the hole of the shaft.
 - (2) Turn vacuum and off and check that the vacuum is turned off at the hole of the shaft.
 - (3) Close the lid and set the spin speed to 1000 rpm. Make sure that the shaft spins and that the tool is reading 1000 rpm.
 - (4) Raise the lid to check the lid interlock. The tool should stop spinning.
 - (5) Ensure that the temperature/humidity sensor is reading on the parameter list.
 - (6) If equipped with optional dispenses, ensure that dispenses are triggering.
 - (7) If equipped with an optional programmable exhaust, ensure it is working properly.
7. Check that the spin chuck(s) with the tool work properly.
 - (1) The spin chucks have a slot that mates with the pin of the spin shaft.
 - (2) Position the spin chuck so the slot and the pin line up and press onto the shaft by hand.
 - (3) Ensure that the pin fully engages the slot.
 - (4) If equipped with a screw, insert screw and tighten.
 - (5) Test vacuum of the spin chuck with a substrate using manual control. Set the vacuum threshold to 64 kPa. If vacuum is less than 64 kPa, the chuck passes inspection.
 - (6) Turn vacuum off and remove the substrate.
 - (7) Removal of spin chuck is reverse of installation.
8. If the tool passes these checks, the tool is ready to operate. Begin by creating a recipe.

4. Developer Use and Operation

4.1. Spin Chuck

1. Locate Spin Chuck Flat head Cap Screw (Located in the center of Vacuum chuck).
2. Use a 3/32" hex key wrench and remove the spin chuck screw from the spindle.
3. Grasp the spin chuck and pull up and remove vertically.
4. Place new spin chucks in the same orientation as old and ensure that the spindle key aligns with chuck slot.
5. Use a 3/32" hex key wrench to secure spin chuck screw in the center of new chuck.

4.2.5- Hole Dispense Nozzle Hub

All Cee® Developer utilize a standard multi-nozzle dispense center hub. This design allows up to five (center-positioned) dispense nozzles to be mounted into the lid simultaneously and triggered independently in any sequence or combination. The auto-dispense nozzles are all angled to the center of the wafer and utilize precision suck-back control. Additionally, each nozzle features a female luer adapter that houses a disposable tip to be placed at the point of use. This tip can easily be changed to clear any dried material residue and/or manipulate the volume of the dispense flow.

4.3. Lid Adjustment

The Apogee™ Developer is furnished with an adjustable lid. This lid allows the operator to regulate the exhaust flow through the bowl region. Adjustments to the lid height can be a variable in optimizing coating results.

To adjust the lid height, use the 3 thumb screws seen from the top of the lid (2 on the rear, and one in the front). Before adjusting, the two bolts on the back of the equipment that mounts the lid assembly to the back plate of the tool must be loosened. The lid is raised by rotating the adjustment knobs counterclockwise and lowered by rotating them clockwise. For best results it is recommended that each knob be adjusted in sequence and not more than one turn per sequence. Once the desire adjustment has been made, tighten back the 2 lid assembly bolts on the back of the equipment.

5. Preventative Maintenance

This maintenance manual provides personnel with procedure and guidelines for maintaining a Cee® Apogee™ Developer. Below is a chart of recommend maintenance scheduling.

Maintenance Section	Maintenance Schedule
Safety Checks	Before daily tool use
Cleaning	After daily tool use
Mechanical Checklist	See Section 5.2 for Details
Utility Checks	See Section 5.3 For Details

5.1. Safety Checks

Inspect developer lid for the following defects:

- (a) Loose assemblies
- (b) Improper closure
- (c) Improper bowl ring placement

5.2. Mechanical Checklist

1. **Spin chuck cleanliness:** If any material has built up on the spin chuck, it can be wiped clean with most organic solvents isopropyl alcohol, or acetone. For major buildup of material, a glass slide can be used to gently scrap the material away. Follow by wiping clean. A dirty spin chuck could cause vacuum errors. See section 2.1 on detailed cleaning instructions. **Daily**
2. **Spin chuck flatness:** This can be seen visually with a straight edge. Small uniformity issues such as a burr can be gently removed with a razor blade or a glass slide. Larger deformations such as a damaged area from dropping can be removed with fine sandpaper. A non-uniform spin chuck can cause vacuum errors. **Quarterly**
3. **Bearing wear:** Rotate the spindle shaft by hand. The shaft should easily spin with little noise. If not bearing should be replaced. If grinding noise is heard during a process, bearing should be replaced. Bad bearings can cause erratic spin speed and acceleration. **Quarterly**
4. **Vacuum liquid trap:** There should be no material in the vacuum trap. Material in the vacuum trap will cause vacuum issues. **Quarterly**
5. **Axial spindle shaft play:** There should be no axial play in the shaft. Axial play will cause excess bearing wear and possible vacuum error. **Bi-annually**

5.3. Utility Checks

1. Check all pressures for ranges specified in tool manual. **Daily**
2. Verify that there is a proper drain facility. **Daily**
3. Verify that the exhaust is functioning. **Daily**
4. Inspect all connections for proper installation. **Bi-Annually**
5. Verify that the AC power is of the proper voltage, and is connected. **Bi-Annually**

5.4. Cleaning

For cleaning, it is good practice to use the mildest solvent possible. The machine cabinet may be cleaned using most organic solvents, acetone, isopropyl alcohol, or N-methylpyrrolidinone (NMP). Caustic acids or bases should not be used. The spin bowl lid may be cleaned with isopropyl alcohol, acetone, or water based cleaners.

Keep solvent from getting into the vacuum system. When cleaning the spin bowl, a small substrate should be on the spin chuck to keep solvent from getting into the vacuum system. Spin the wafer at approximately 200 RPM, and use solvent in a wash bottle to flush out the spin bowl. Keep solvent from going down the spin shaft or the spin shaft tube. Shields and seals will protect the bearings from a small amount of solvent, but they will not be able to handle large doses. Do not direct the solvent stream down the shaft or tube.

Avoid getting solvent of any kind on the small yellow "Hot Surface" labels. Use only water-based cleaner on the labels on the rear of the machine. Use only isopropyl or water based cleaner on the "power on-off", Cee® logo, the yellow "Caution ... Eye Protection", and the "Cee® model/serial number" labels. The display may be cleaned with glass cleaner, water, or isopropyl alcohol.