

APOGEE BAKE PLATE FLANGE MOUNT OPTION

EXHAUST HOOD DIMENSIONS

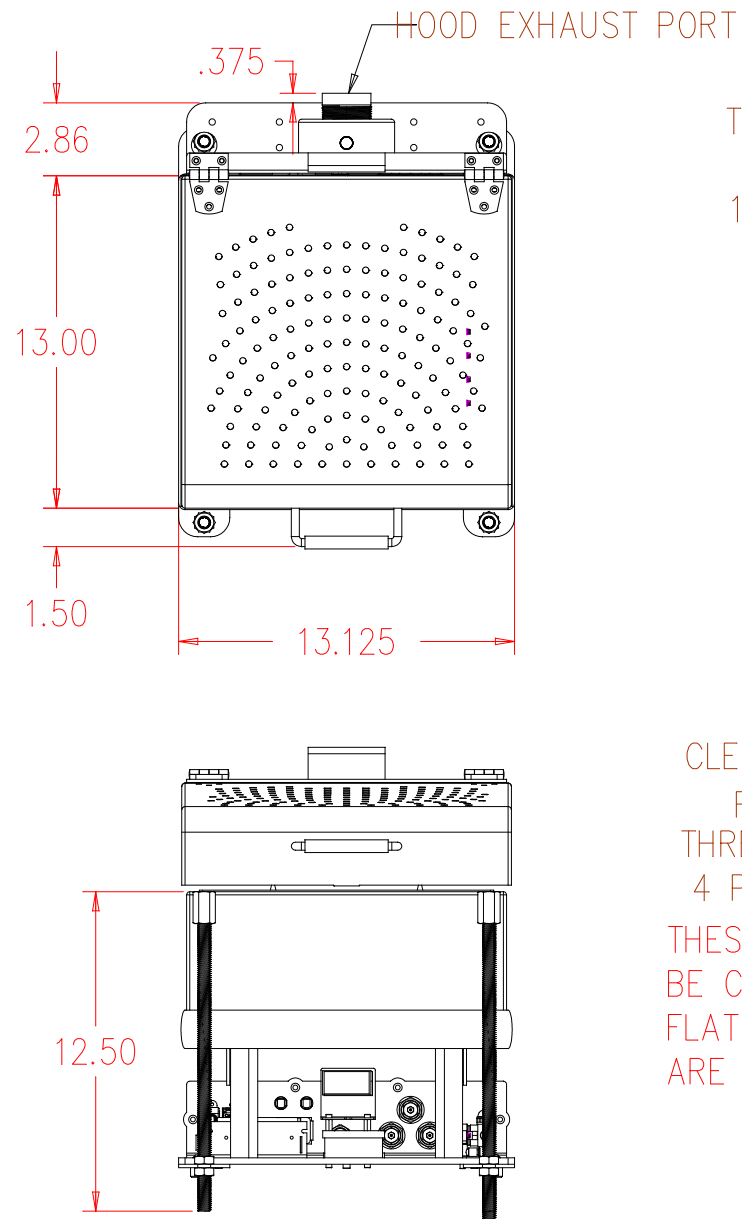

MACHINE DEPTH

TABLE TOP CUT-OUT AND MOUNTING HOLES

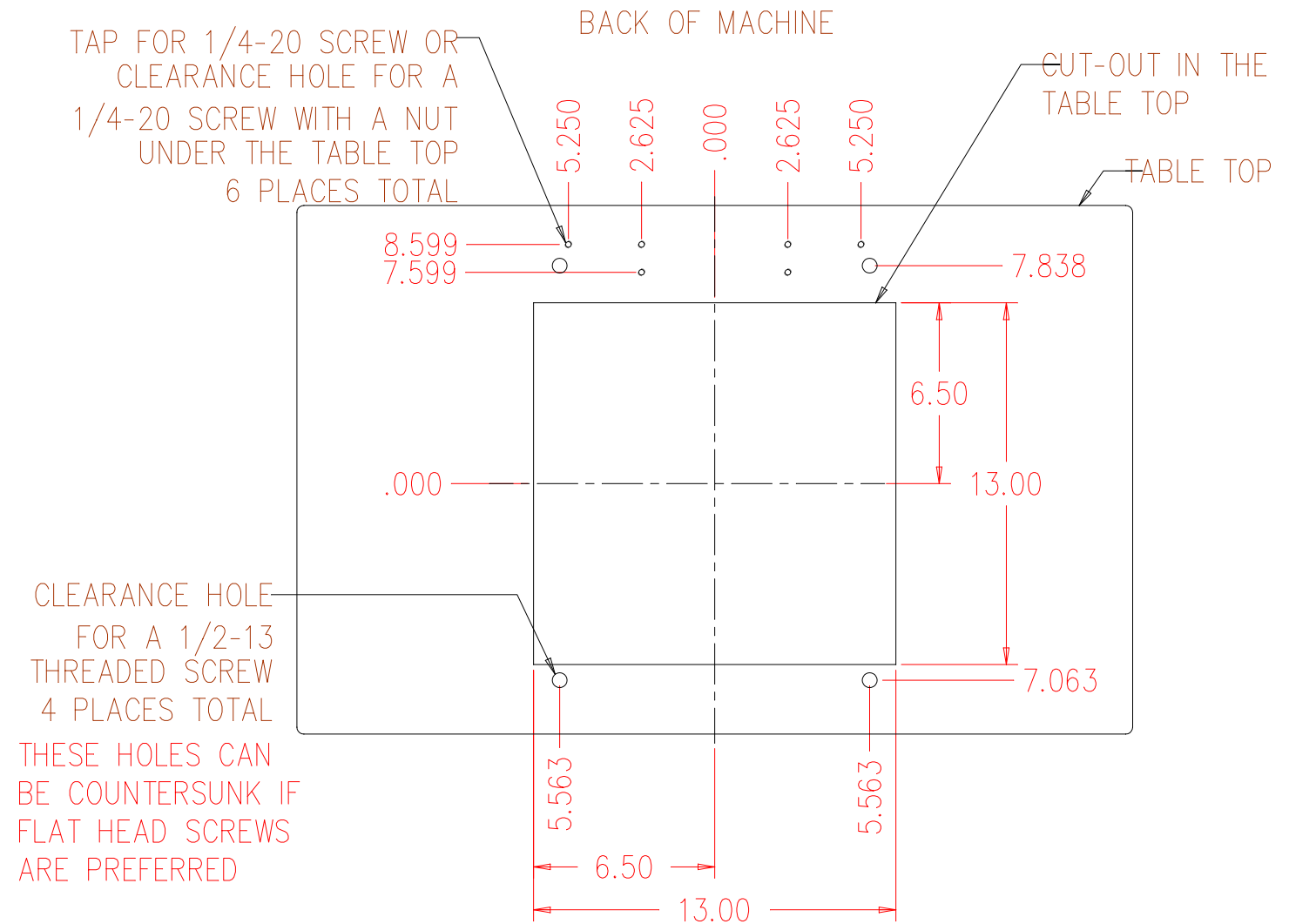

CLEARANCE HOLE FOR A 1/2-13 THREADED SCREW 4 PLACES TOTAL THESE HOLES CAN BE COUNTERSUNK IF FLAT HEAD SCREWS ARE PREFERRED

DIMENSIONS ARE INCHES

SCALE 1: 1	THIRD ANGLE PROJECTION	DESIGN ENGINEER	Cost Effective Equipment 3703 HyPoint Blvd Rolla, MO 65401 Phone: (573) 466-4300
ALL DIMENSIONS ARE BASIC UNLESS OTHERWISE NOTED. LIMITS ON DIMENSIONS ARE		DRAWN BY	
DECIMALS .XX=±.015 .XXX=±.005 .XXXX=±.0005 FRACTIONS ±1/64		APPROVED	TITLE
THESE DRAWINGS/SPECIFICATIONS ARE THE EXCLUSIVE PROPERTY OF COST EFFECTIVE EQUIPMENT, LLC. THEY SHALL NOT BE REPRODUCED OR COMMUNICATED TO OTHERS, IN WHOLE OR IN PART, NOR BE USED AS A BASIS FOR MANUFACTURE OR SALE OF THE ITEMS REPRESENTED, WITHOUT THE WRITTEN PERMISSION OF COST EFFECTIVE EQUIPMENT, LLC.		DATE 3/8/2019	Apogee Bake Plate Flange Utilities SIZE B SHEET 1 of 2 CONTROLLER

REVISIONS				
REV	DESCRIPTION	DATE	APPROVED	

APOGEE FLANGE MOUNT CONTROL CONSOLE
MOUNTING PANEL CUTOUT DIMENSIONS
HOLE PATTERN AND CUTOUT ARE SYMMETRIC

CONTROL FLANGE SUPPLIED
WITH $\varnothing 1/4"$ (6MM) HOLES
8 PLACES

A 1/2" CORNER RADIUS
(12MM) MAX. IS PERMISSIBLE
BUT NOT REQUIRED
4 PLACES

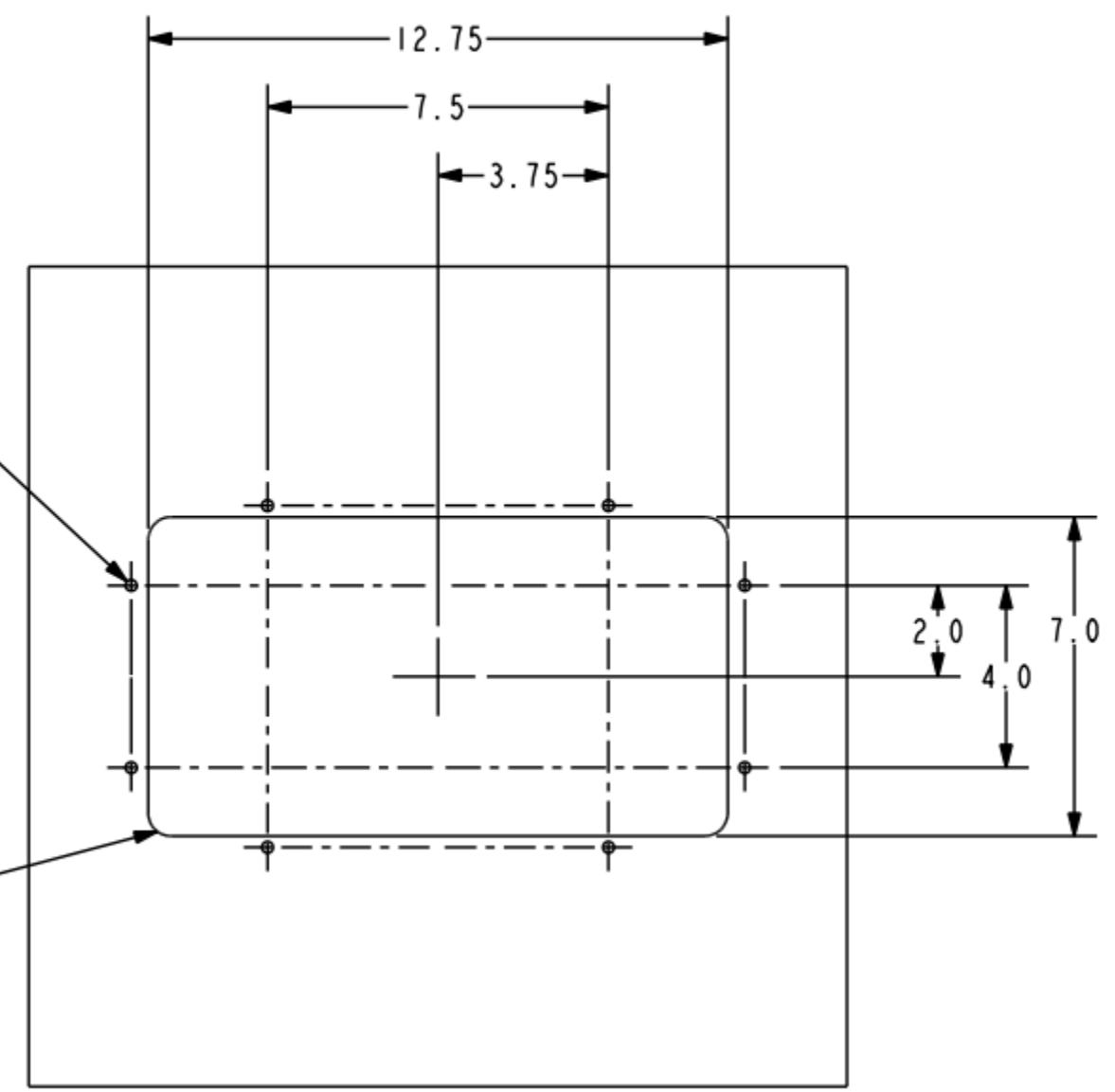

SCALE 1:1	THIRD ANGLE PROJECTION	DESIGN ENGINEER	 Cost Effective Equipment 3703 HyPoint Blvd Rolla, MO 65401 Phone: (573) 466-4300
ALL DIMENSIONS ARE BASIC UNLESS OTHERWISE NOTED. LIMITS ON DIMENSIONS ARE	ANGLES $\pm 1^\circ$	DRAWN BY	
DECIMALS .XX \pm .015 .XXX \pm .005 .XXXX \pm .0005	FRACTIONS $\pm 1/64$	APPROVED	TITLE Apogee Bake Plate Flange Utilities
THESE DRAWINGS/SPECIFICATIONS ARE THE EXCLUSIVE PROPERTY OF COST EFFECTIVE EQUIPMENT, LLC. THEY SHALL NOT BE REPRODUCED OR COMMUNICATED TO OTHERS, IN WHOLE OR IN PART, NOR BE USED AS A BASIS FOR MANUFACTURE OR SALE OF THE ITEMS REPRESENTED, WITHOUT THE WRITTEN PERMISSION OF COST EFFECTIVE EQUIPMENT, LLC.		DATE 3/8/2019	SIZE B
REVISIONS		MATERIAL	PART NO.
REV	DESCRIPTION	DATE	APPROVED
		FINISH	SHEET 2 of 2
			CONTROLLER