

# MACHINE INSTALLATION REQUIREMENTS:

POWER CORD (NOT SUPPLIED): 10AWG, 3 CONDUCTOR SOOW FLEXIBLE RUBBER CORD OR EQUIVALENT UNDER 20ft LONG

LOCK OUT/TAG OUT DEVICES (NOT SUPPLIED) MUST BE INSTALLED AT THE ELECTRICAL SUPPLY, VACUUM SUPPLY AND NITROGEN SUPPLY TO COMPLY WITH CE MARK REQUIREMENTS (IF NECESSARY)

## FOOTPRINT DIMENSIONS:

WITH ATTACHED DISPLAY:  
49" L x 39.5" D x 57.5" H (125 cm L x 100 cm D x 146 cm H)

WITH DISPLAY ON A 10ft UMBILICAL CORD OPTION:  
49" L x 32.5" D x 57.5" H (125 cm L x 83 cm D x 146 cm H)

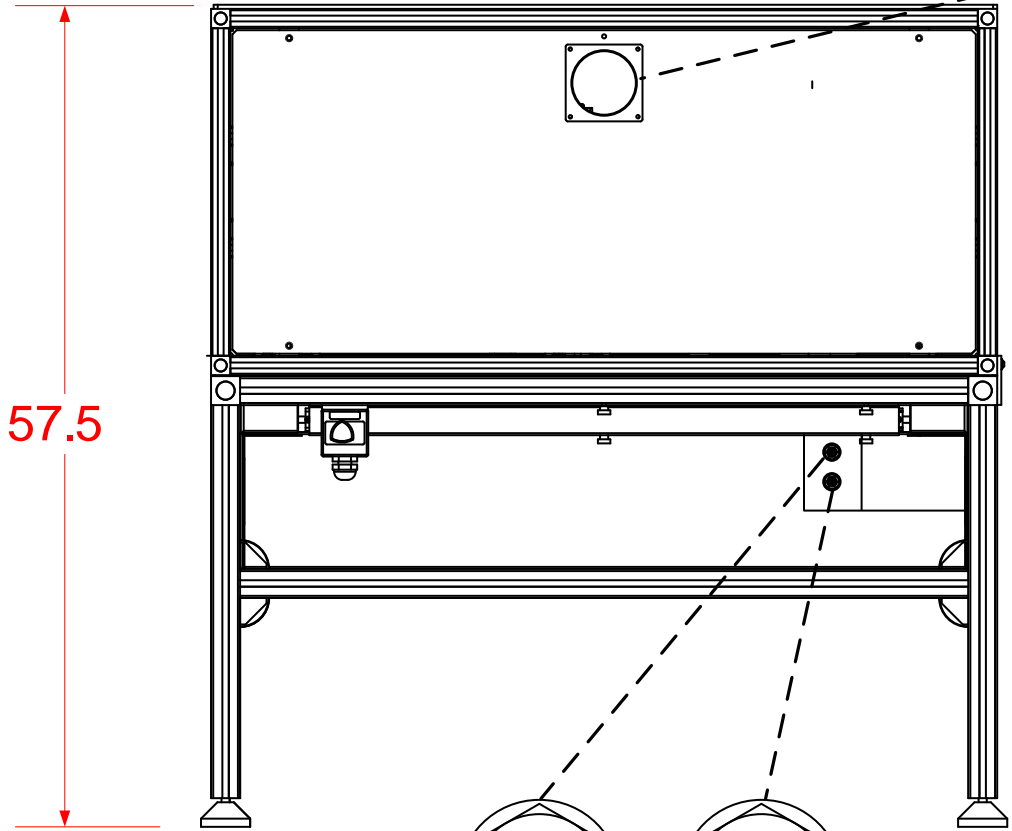
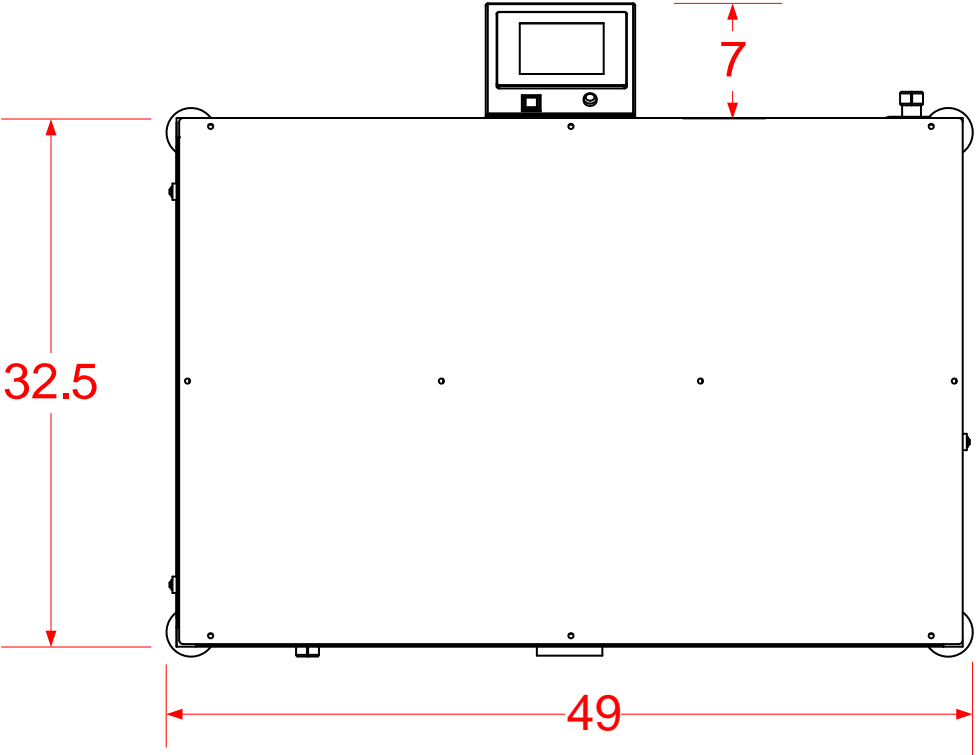

4" OD EXHAUST PORT

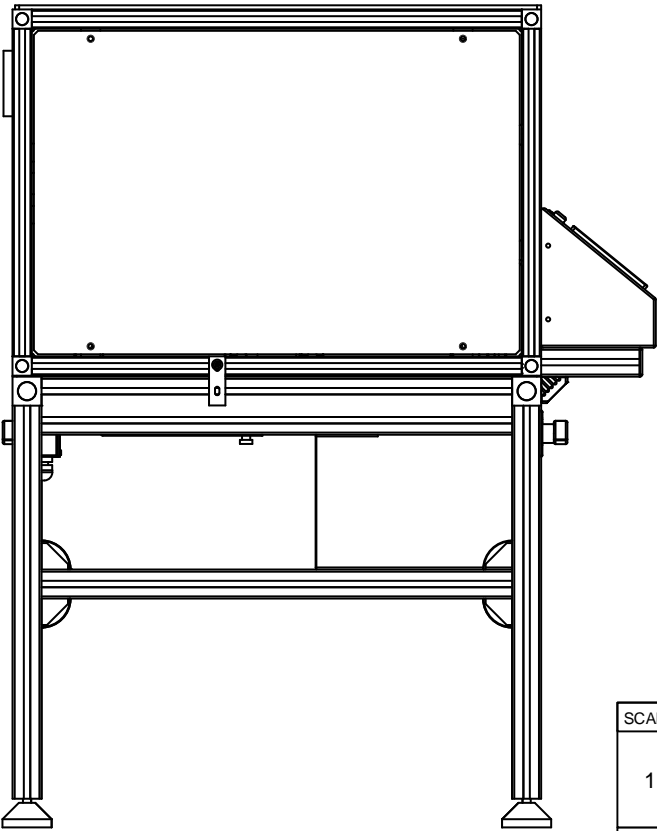

NITROGEN INLET  
1/4" PUSH TO CONNECT



VACUUM INLET  
1/4" PUSH TO CONNECT

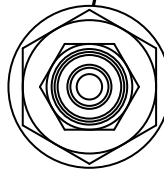

**Required Utilities:**

Power: 208-240VAC 4500W, 50/60 Hz, Single Phase  
Fuse: 30A

90 psi Nitrogen (0.5 cfm / 15 lpm) – 1/4" Push To Connect  
27" Hg Vacuum (5.0 cfm) – 1/4" Push To Connect

Exhaust: 4" OD Duct (20-50cfm @ 0.2 W.G.)

SCALE 1:1	THIRD ANGLE PROJECTION	DESIGN ENGINEER	 Cost Effective Equipment 3703 HyPoint Blvd Rolla, MO 65401 Phone: (573) 466-4300
ALL DIMENSIONS ARE BASIC UNLESS OTHERWISE NOTED. LIMITS ON DIMENSIONS ARE		DRAWN BY	
DECIMALS .XX=±.015 .XXX=±.005 .XXXX=±.0005 ANGLES ±1° FRACTIONS ±1/64		APPROVED	TITLE 1300CSX SLIDE DEBONDER UTILITIES
THESE DRAWINGS/SPECIFICATIONS ARE THE EXCLUSIVE PROPERTY OF COST EFFECTIVE EQUIPMENT, LLC. THEY SHALL NOT BE REPRODUCED OR COMMUNICATED TO OTHERS, IN WHOLE OR IN PART, NOR BE USED AS A BASIS FOR MANUFACTURE OR SALE OF THE ITEMS REPRESENTED, WITHOUT THE WRITTEN PERMISSION OF COST EFFECTIVE EQUIPMENT, LLC.		DATE 3/21/2019	SIZE B
REVISIONS		MATERIAL	PART NO.
REV	DESCRIPTION	FINISH	SHEET 1 of 1
	DATE		CONTROLLER
	APPROVED		