

www.costeffectiveequipment.com

+1-573-466-4300

Operations Manual

Apogee® Bake Plate

Models: A-B-B2-1

A-B-B2-2



Cee
Cost Effective Equipment

1	INTRODUCTION	4
1.1	CONFIDENTIALITY STATEMENT	4
1.2	WARRANTY	4
1.3	RETURNED MATERIALS	4
1.4	MODEL AND REVISIONS	4
1.5	ENVIRONMENTAL CONSIDERATIONS	5
1.6	GENERAL SAFETY HAZARDS / PRECAUTIONS	5
1.7	ELECTRICAL	6
1.8	MECHANICAL	6
1.9	THERMAL	6
1.10	CHEMICAL	7
1.11	LOCKOUT/TAGOUT PROCEDURES AND INFORMATION	8
1.12	INTENDED USE OF MACHINE	8
2	EQUIPMENT DESCRIPTION	9
2.1	USER CONTROLS	9
2.2	DIMENSIONS	9
2.3	FEATURES & PROGRAMMABILITY	10
2.4	PRECISION	10
2.5	RELIABILITY	10
2.6	NRTL	10
2.7	UTILITIES	11
3	INSTALLATION	12
3.1	CLEARANCE REQUIREMENTS	12
3.2	FACILITIES REQUIREMENTS	13
3.3	ENVIRONMENT	13
3.4	UNPACKAGING & INSPECTION	14
3.5	SYSTEM INSTALLATION & SETUP	14
3.6	START UP	14
3.7	SYSTEM CHECKS	15
4	DATASTREAM™ TECHNOLOGY	18
4.1	SYSTEM PARAMETERS	18
4.2	MANUAL CONTROLS – APOGEE® BAKE PLATE	18
4.3	PREPARATION	23
4.4	RUNNING RECIPES	25
4.5	EDITING RECIPES	26
4.6	TOOL SPECIFIC SETTINGS – APOGEE® BAKE PLATE	26
5	BAKE PLATE THEORY	27
5.1	BAKE PLATES VS CONVENTIONAL OVENS	27
5.2	THE SKIN EFFECT	27
5.3	HOTPLATE BAKE VARIABLES AND METHODS	28
5.4	BAKE TEMPERATURE	28
5.5	BAKE METHODS	28
5.6	BAKE TIME	29
5.7	EXHAUST COVER	29
5.8	OVEN VS BAKE PLATE EXAMPLES	29
5.9	REFLOW SOLDERING	30
5.10	BAKE PLATE PROCESS TROUBLESHOOTING	30

6 PREVENTATIVE MAINTENANCE 31

- 6.1 SERVICE AND REPAIRS 31
- 6.2 FAULT CONDITION 31
- 6.3 SAFETY CHECKS 31
- 6.4 MECHANICAL/UTILITIES CHECKLIST 31
- 6.5 CLEANING 32

7 TABLE OF REVISIONS 33

1 Introduction

1.1 Confidentiality Statement

Information supplied is for use in the operation and/or maintenance of Cee® equipment. Neither this document nor the information it contains shall be disclosed to others for manufacturing or any other purpose without written authorization from Cost Effective Equipment, LLC.

1.2 Warranty

Cost Effective Equipment, LLC warrants to the original purchaser (Buyer) that equipment is free from defects in material and workmanship under normal use and service in accordance with Cee® instructions and specifications. Buyer shall promptly notify Cee® of any claim against this warranty, and any item to be returned to Cee® shall be sent with transportation charges prepaid by Buyer, clearly marked with a Return Authorization (RMA) number obtained from Cee® Customer Support. Cee's obligation under this warranty is limited to the repair or replacement, at Cee's option, of any equipment, component or part which is determined by Cee® to be defective in material or workmanship. This obligation shall expire one (1) year after the initial shipment of the equipment from Cee®. This warranty shall be void if:

- Any failure is due to the misuse, neglect, improper installation of, or accident to the equipment.
- Any major repairs or alterations are made to equipment by anyone other than a duly authorized representative of Cee®. Representatives of Buyer will be authorized to make repairs to the equipment without voiding warranty, on completion of the Cee® training program.
- Replacement parts are used other than those made or recommended by Cee®.

CEE® MAKES NO OTHER WARRANTIES, EXPRESSED OR IMPLIED, WITH RESPECT TO EQUIPMENT. NO WARRANTY IS MADE AS TO THE MERCHANTABILITY OF THE EQUIPMENT NOR ITS FITNESS FOR ANY PARTICULAR PURPOSE. In no event shall Cee® be liable for consequential loss or damages, however caused. No person or representative of Cee® is authorized to assume for Cee® any liability in connection with equipment nor to make any change to this warranty unless such change or modification is put in writing and approved by an authorized representative of Cee® in writing.

This warranty shall be governed by the laws of the state of Missouri, U.S.A.

1.3 Returned Materials

Any materials, parts, or equipment returned to Cost Effective Equipment, LLC must be clearly labeled with a Return Material Authorization (RMA) number.



To obtain an RMA number, contact:

Cost Effective Equipment, LLC Customer Support
Telephone +1-573-466-4300
Email..... support@costeffectiveequipment.com
Web Address..... www.costeffectiveequipment.com
Physical Address..... 6 Industrial Drive; St. James, Missouri 65559



1.4 Model and Revisions

The model and serial number information for the Cee® Apogee® Bake Plate are located on the rear panel. Software version information can be found on the *About* screen. Refer to the [DataStream™ Manual](#) for screen shots and a detailed explanation of the system software.



1.5 Environmental Considerations

	<p>Cee® fosters sustainability through innovation in the durability and reliability of our precision tools and equipment. Individual component modules are engineered for serviceability ensuring long lasting performance. Processes are designed to minimize use & consumption of chemical compounds ensuring accurate, replicable, industry-leading results every time.</p>	<p>Cee® favorise la durabilité grâce à l'innovation dans la durabilité et la fiabilité de nos outils et équipements de précision. Les modules de composants individuels sont conçus pour une facilité d'entretien garantissant des performances durables. Les processus sont conçus pour minimiser l'utilisation et la consommation de composés chimiques, garantissant à chaque fois des résultats précis, reproductibles et à la pointe de l'industrie.</p>
	<p>Cee® diligently screens suppliers to ensure conflict-free sourcing of minerals and product components are constructed of recycled materials wherever possible.</p>	<p>Cee® sélectionne avec diligence les fournisseurs pour garantir que l'approvisionnement en minéraux est sans conflit et que les composants des produits sont fabriqués à partir de matériaux recyclés dans la mesure du possible.</p>
	<p>Cee® tools and equipment operate without the use of ozone depleting substances (ODSs) including chlorofluorocarbons (CFCs), methyl chloroform, hydrochlorofluorocarbons (HCFCs), carbon tetrachloride, perfluoro compounds (PFCs), or other volatile compounds/organic solvents.</p>	<p>Les outils et équipements Cee® fonctionnent sans utilisation de substances appauvrissant la couche d'ozone (SACO), notamment les chlorofluorocarbures (CFC), le méthyle chloroforme, les hydrochlorofluorocarbures (HCFC), le tétrachlorure de carbone, les composés perfluorés (PFC) ou d'autres composés volatils/solvants organiques.</p>





1.6 General Safety Hazards / Precautions

	<p>Read this manual in its entirety before operating or servicing the machine.</p>	<p>Lisez ce manuel dans son intégralité avant d'utiliser ou d'entretenir la machine.</p>
	<p>The unit is very heavy and proper precautions should be taken when handling the machine to minimize the risk of injury. Labels are placed on the machine to identify areas where caution is needed during operation.</p>	<p>L'unité est très lourde et des précautions appropriées doivent être prises lors de la manipulation de la machine pour minimiser le risque de blessure. Des étiquettes sont placées sur la machine pour identifier les zones où des précautions sont nécessaires pendant le fonctionnement.</p>
	<p>Sound pressure measurements greater than 80dB(A) are considered hazardous. The following sound pressure measurements were obtained from the Cee® Apogee® 300 Bake Plate at a distance of 3 ft (0.9 m) from the system:</p> <p>Stand-by Mode: 40dB(A) Normal Operations: 40dB(A)</p>	<p>Les mesures de pression acoustique supérieures à 80 dB(A) sont considérées comme dangereuses. Les mesures de pression acoustique suivantes ont été obtenues à partir de la plaque de cuisson Cee® Apogee® 300 à une distance de 3 pieds (0,9 m) du système:</p> <p>Mode veille: 40 dB(A) Fonctionnement normal: 40 dB(A)</p>

1.7 Electrical

	High voltage is present in the machine. Disconnect power before servicing.	Une haute tension est présente dans la machine. Débranchez l'alimentation avant l'entretien.
	Stored electrical energy is present in the machine. Before servicing allow sufficient time for discharge.	L'énergie électrique stockée est présente dans la machine. Avant l'entretien, prévoyez suffisamment de temps pour la décharge.
	This unit must be connected to an outlet with proper grounding.	Cet appareil doit être connecté à une prise avec une mise à la terre appropriée.

1.8 Mechanical

	This machine may contain compressed gases which can provide motive force for components and can expand violently upon decompression. Disconnect N2 or CDA before removing any panels.	Cette machine peut contenir des gaz comprimés qui peuvent fournir une force motrice aux composants et peuvent se dilater violemment lors de la décompression. Débranchez le N2 ou le CDA avant de retirer les panneaux.
	Ensure that all panels are on and in their correct locations before powering up or operating.	Assurez-vous que tous les panneaux sont allumés et à leur emplacement correct avant la mise sous tension ou l'utilisation.
	When opening lids be aware of the pinch point at the hinge cover. Open lids only by using the handles on the lids.	Lorsque vous ouvrez les couvercles, faites attention au point de pincement au niveau du cache de la charnière. Ouvrez les couvercles uniquement en utilisant les poignées des couvercles.
	When operating lid, be aware of the risk of the lid falling and crushing/closing down on fingers/hands.	Lorsque vous utilisez le couvercle, soyez conscient du risque de chute et d'écrasement/fermeture du couvercle avec les doigts/mains.

1.9 Thermal

	Bake Plates can reach temperatures sufficient to cause severe burns and may remain hot for a long-time following operation. Do not service the machine until all surfaces have cooled to a safe thermal condition (e.g., room temperature).	Les plaques de cuisson peuvent atteindre des températures suffisantes pour provoquer de graves brûlures et peuvent rester chaudes longtemps après l'opération. N'entretenez pas la machine tant que toutes les surfaces n'ont pas refroidi à un état thermique sûr (par exemple, température ambiante).
---	---	---





1.10 Chemical

Cee® does not supply or dictate chemicals to be used in conjunction with the Cee® Apogee® 300 Bake Plate. Material data will be reviewed during equipment design and configuration to ensure compatibility with the customer's proprietary process.

Prior to introducing new chemicals, refer to your chemical supplier's factory specifications and MSDS. Material Safety Data Sheets (MSDS) contain crucial information regarding chemical safety, including details about hazardous components, physical properties, spill and leak procedures, waste disposal guidelines, and personal protective equipment requirements for handling.

Cee® ne fournit ni n'impose aucun produit chimique à utiliser avec la plaque de cuisson Cee® Apogee® 300. Les données matérielles seront examinées lors de la conception et de la configuration de l'équipement pour garantir la compatibilité avec le processus exclusif du client.

Avant d'introduire de nouveaux produits chimiques, reportez-vous aux spécifications d'usine et à la fiche signalétique de votre fournisseur de produits chimiques. Les fiches signalétiques (MSDS) contiennent des informations cruciales concernant la sécurité chimique, notamment des détails sur les composants dangereux, les propriétés physiques, les procédures en cas de déversement et de fuite, les directives d'élimination des déchets et les exigences en matière d'équipement de protection individuelle pour la manipulation.

	<p>Ensure chemical compatibility of all chemicals and materials being used inside the machine. This includes all wetted parts of the storage, supply, dispense, and waste systems.</p>	<p>Assurer la compatibilité chimique de tous les produits chimiques et matériaux utilisés à l'intérieur de la machine. Cela inclut toutes les parties mouillées des systèmes de stockage, d'alimentation, de distribution et de déchets.</p>
	<p>Potential for flammable Chemicals. No open flames/sparks.</p>	<p>Potential de produits chimiques inflammables. Pas de flammes nues/étincelles.</p>
	<p>Relieve pressure and shut off chemical valves before servicing supply lines, dispense valves or other components.</p>	<p>Relâchez la pression et fermez les vannes chimiques avant d'entretenir les conduites d'alimentation, les vannes de distribution ou d'autres composants.</p>
	<p>Ensure proper ventilation/exhaust is always used.</p>	<p>Assurez-vous qu'une ventilation/évacuation adéquate est toujours utilisée.</p>
	<p>Always wear appropriate Personal Protective Equipment. This includes safety glasses, gloves, and other equipment, as needed, to protect from mechanical and chemical hazards.</p>	<p>Portez toujours un équipement de protection individuelle approprié. Cela comprend des lunettes de sécurité, des gants et tout autre équipement, si nécessaire, pour se protéger des risques mécaniques et chimiques.</p>
<p>Exhaust and fume management is important to prevent the release of hazardous materials and ensure a safe working environment. Users should assume that all fumes are hazardous and take appropriate precautions to ensure system exhaust is functional per the guidelines outlined in section 6 of this manual.</p>		<p>La gestion des gaz d'échappement et des fumées est importante pour empêcher le rejet de matières dangereuses et garantir un environnement de travail sûr. Les utilisateurs doivent supposer que toutes les fumées sont dangereuses et prendre les précautions appropriées pour garantir que l'échappement du système est fonctionnel conformément aux directives décrites dans la section 6 de ce manuel.</p>

1.11 Lockout/Tagout Procedures and Information

Before servicing, turn off the machine and remove the power inlet cord by disconnecting the plug where it enters the machine.

Note: There are no LOTO (Lock Out/Tag Out) facilities supplied with the Cee® Apogee® Bake Plate. It is the responsibility of the customer/installer/end-user to ensure that the suitable LOTO devices are provided on utilities being supplied to the Cee® Apogee® Bake Plate in accordance with applicable laws, regulations, and/or company policies.

For more information, please contact [Cee® Customer Support](#).

1.12 Intended Use of Machine

The Cee® Apogee® Bake Plate is intended for use as a semiconductor/optical application machine.

The Cee® Apogee® Bake Plate is not intended for use in food or medical applications or for use in hazardous locations.

The Cee® Apogee® Bake Plate is intended for use only by trained personnel wearing the proper personal protective equipment. Anyone not trained in the proper use of the Cee® Apogee® Bake Plate and having not fully read this manual, should not operate the equipment.

The Cee® Apogee® Bake Plate is intended for use in a cleanroom environment to provide the proper processing conditions for substrates. If it is used outside of a cleanroom environment, substrate cleanliness may be compromised.

The Cee® Apogee® Bake Plate is not intended for use in a hazardous or explosive environment.

Normal Operating Conditions

The Cee® Apogee® Bake Plate is designed for indoor use only.

Ambient Temperature 10°C - 30°C

Relative Humidity ≤80%

Altitude up to 3000 m

Pollution Degree..... 2

Oversoltage Category II

Permissible Voltage Fluctuations 208-230VAC ±10%



If the Cee® Apogee® 300 Bake Plate is used in a manner not specified by Cee® or with accessories not provided by Cee® the protection provided by the equipment may be impaired.

Si la plaque de cuisson Cee® Apogee® 300 est utilisée d'une manière non spécifiée par Cee® ou avec des accessoires non fournis par Cee®, la protection fournie par l'équipement peut être altérée.

2 Equipment Description

The Cee® Apogee® Bake Plate features a revolutionary intuitive interface, a space-saving design, and track-quality thermal accuracy and uniformity.

Fully programmable and user-friendly, the Cee® Apogee® Bake Plate features the accuracy and repeatability needed to eliminate processing variability from critical experiments. Recipes are easily entered, monitored, and stored with the convenient full-color touch screen interface and onboard DataStream™ Technology. Compact footprint, intuitive design, and unparalleled manufacturer experience add up to years of high-performance bake step processing, perfect for any low-volume or R&D laboratory processing environment.

2.1 User Controls

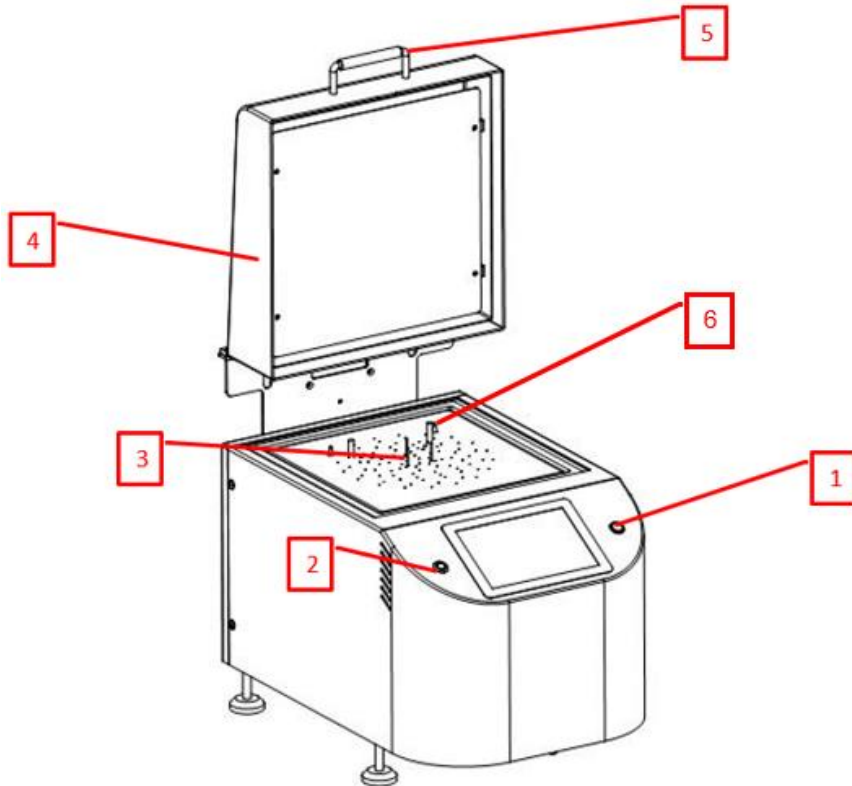

Figure 1: Cee® Apogee® Bake Plate User Controls

1. power button used to turn equipment off and on
2. user presence button¹ facilitates remote access
3. lift pins lifts and lowers the substrate
4. bake plate lid cover for the bake plate working surface
5. lid handle enables safe opening and closing of the lid
6. stop pins for precise wafer positioning

2.2 Dimensions

- 13.25" (336.6mm) W × 21" (533.4mm) D × 17.25" (438.15mm) H
- machine weight..... 65lbs (29.5kg)

¹ See [DataStream™ Manual](#) for more information

2.3 Features & Programmability

- compact design for minimized footprint
- full-color touchscreen graphical user interface (GUI)
- durable wet bench design can be converted to a flange/deck mountable configuration
- supports unlimited bake process programs/program steps per recipe
- 0.1 second step time resolution (9,999.9 seconds maximum step time)
- three automated bake methods: contact, vacuum, proximity (N₂ or lift pins)
- bake plate auto-sizing for 3" and 100mm, 125mm, 150mm, and 200mm substrates²
- up/download DataStream™ process parameters via native USB and Ethernet ports
- height programmed in 0.1 increments with an overall range of 0-19mm
- exhausted hood for removal of process chemical fumes
- optional nitrogen purge for inert bake environment
- substrate sizes of <10mm to 200mm round; 8" x 8" square

2.4 Precision

- temperature resolution 0.1°C
- temperature range..... ambient to 300°C (400°C optional)
- temperature uniformity ± 0.3% across working surface

2.5 Reliability

- industry-leading Cee® Apogee® reliability and uptime
- one-year full warranty on parts and labor
- complimentary remote technical support and application process assistance for the life of the product

2.6 NRTL

Beginning in June of 2024, all standard Cee® Apogee® Bake Plate models will proudly showcase the TÜV SÜD NRTL mark, a testament to our commitment to safety and quality.

The TÜV SÜD NRTL mark signifies compliance with North American safety standards, providing assurance of product safety and quality. Recognized by Authorities Having Jurisdiction (AHJs) and code officials throughout the US and Canada, the TÜV SÜD Mark is featured on millions of products sold nationwide. Customers can trust that products bearing the TÜV SÜD Mark meet rigorous safety standards established by independent testing and ongoing inspections.

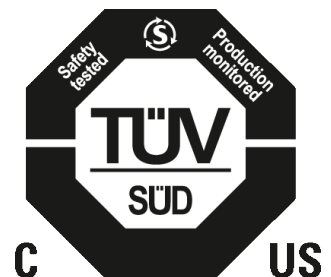

² Equipment may allow for custom sized substrates based on customer request.

2.7 Utilities

- voltage ranges..... 100-120; 208-230 VAC, single phase 50/60 Hz
- power requirements 1638W (13.3A); 1513W (6.6A) *max*
- exhaust port..... 2" OD, 0.4" H₂O@10CFM (100Pa@17 CMH)
- vacuum..... 20 inHg (33kPa abs)
- N₂..... 35psi (241kPa)

3 Installation

3.1 Clearance Requirements

The Cee® Apogee® Bake Plate is a benchtop unit requiring a table or benchtop for location. In most cases the supporting structure will be larger than the unit itself.

Clearance Requirements

device rear 12" (304.8mm)
device sides 3" (76.2mm)

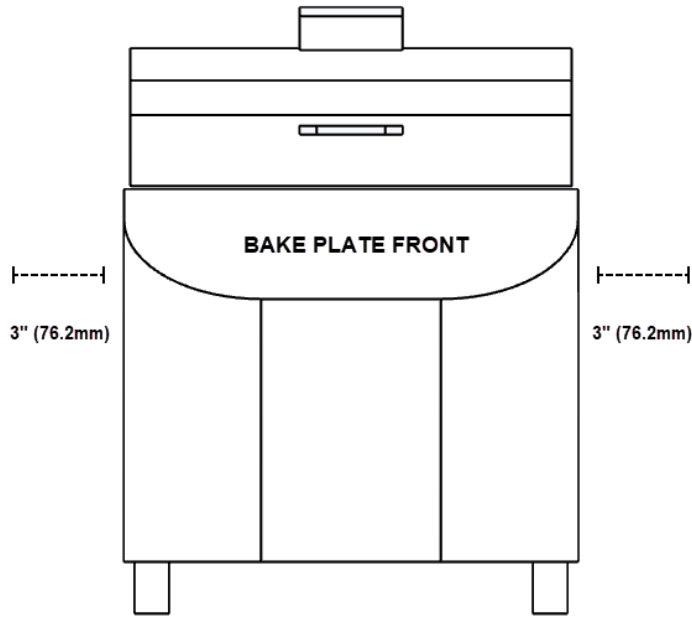

Figure 2: Apogee® Bake Plate Side Clearance Requirements

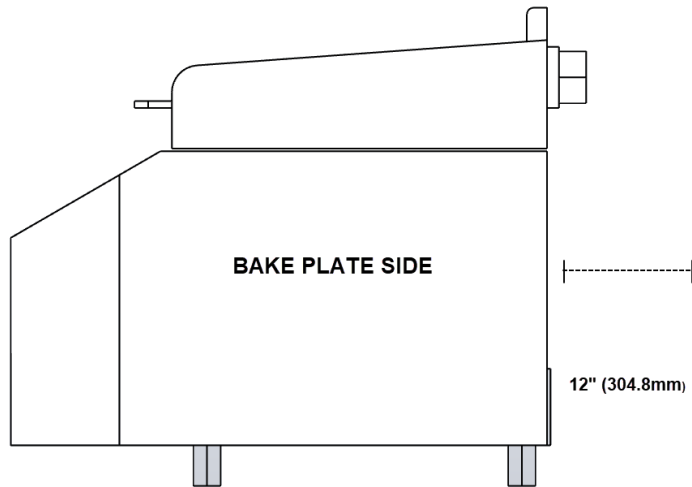

Figure 3: Apogee® Bake Plate Rear Clearance Requirements

3.2 Facilities Requirements

The Cee® Apogee® Bake Plate requires the following utilities for operation.

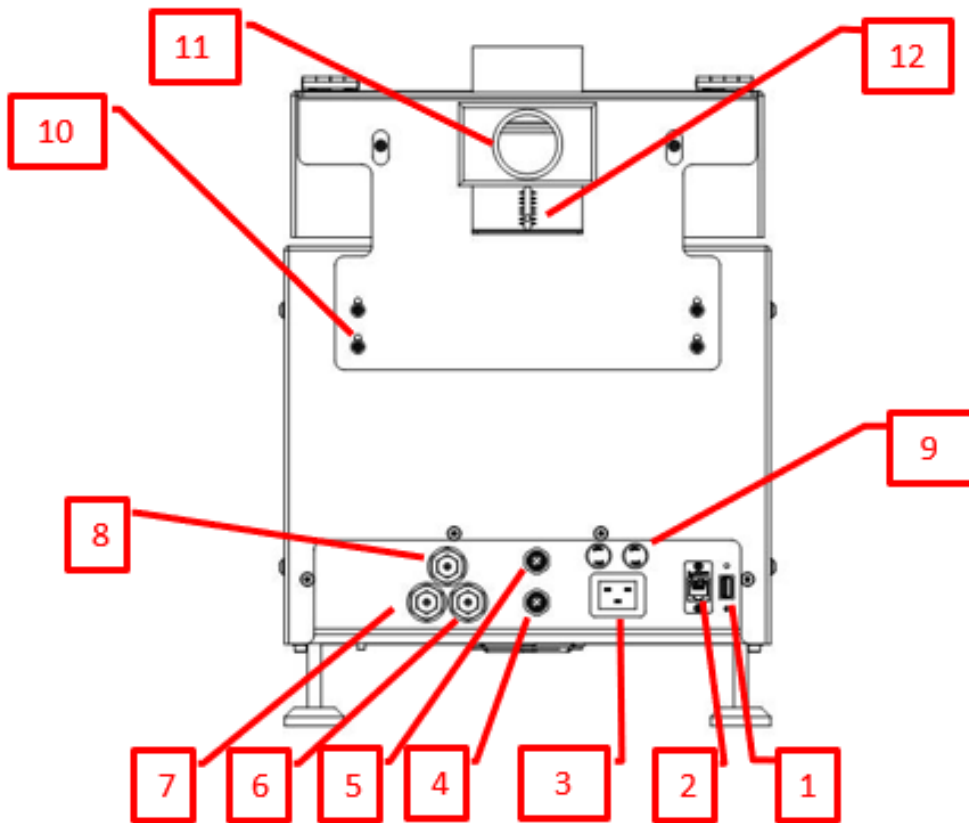

Figure 4: Apogee® Bake Plate Facilities Connections

1. USB port facilitates software updates and log file downloads
2. Ethernet enables remote recipe writing remote device control
3. AC power in³ single phase 100-120 VAC at 13.3A
4. accessory port enables communication with external I/O devices as needed
5. light tree port for optional light tree
6. vacuum accessory supply connection for accessories items (e.g., vacuum wands)
7. system vacuum system vacuum for bake plate surface
8. system N₂ system nitrogen for proximity bake on the bake plate surface
9. fuses system protection fuses (Replacement: BK/MDA-15-R – 15A; 250VAC max)
10. hood height adjustment used to adjust the gap beneath the hood
11. exhaust port exhaust port for bake plate vapors
12. exhaust gate used to adjust the flow rate of exhaust on the bake plate

3.3 Environment

The Cee® Apogee® Bake Plate should be operated in a clean, low humidity environment.

³ (208-230VAC option available, see back to verify)

3.4 Unpackaging & Inspection

1. Lifting from the bottom of the unit, carefully remove from packing crate. Do not lift by any of the top covers or protrusions. Do not roll or turn the unit on its sides.
2. Remove packing foam and plastic wrap.
3. Place the Cee® Apogee® Bake Plate on a table of proper height and strength so that the controls and bake surface are at an ergonomically appropriate height.
4. Thoroughly check the machine for shipping damage. If physical damage is apparent, ***DO NOT APPLY POWER!*** Contact [Cee® Customer Support](#) immediately.

**All Apogee® Bake surface plates are Type III anodized aluminum and conform to industry specifications for hardness and durability. Please note that the color of the surface plates may vary due to the anodizing process. This variance in color does not affect the quality, functionality, or performance of the product.*

The following items are included with shipment:

- Cee® Apogee® Bake Plate
- (x2) stop pins
- temperature & humidity sensor
- power cord
- operations manual (USB thumb drive)
- quick reference card

Optionally Included Items:

- vacuum pump
- light tree
- N₂ purge hood
- plastic tipped lift pins
- chill station

3.5 System Installation & Setup

Please refer to the quick reference card supplied with the tool.

1. Using (x2) 9/16" wrenches, turn the adjustable feet until there is 1 ¼" – 1 ¾" between the tabletop and bottom of the equipment. Using the adjustable feet, first level the Cee® Apogee® Bake Plate then adjust so that the bake surface tilts slightly back sufficiently that when using *proximity mode*, the wafer floats against the stop pins and not off the front of the chuck.
2. Thoroughly clean the bake plate surface according to instructions outlined in the *Preventative Maintenance* section of this manual.
3. Connect utilities according to the *Facilities Requirements* diagram in section 3.2
4. Connect the temperature & humidity sensor to the CAN terminal
5. Connect the vacuum supply to the vacuum fitting
6. Connect the nitrogen supply to the nitrogen fitting
7. Connect exhaust lines to the exhaust port
8. Plug in the machine and note that only the cooling fan should be powered, not the display.

3.6 Start Up

Once the preliminary setup steps outlined in section 3 have been completed, press the lighted *Power* switch to turn the tool on. The display will cycle through a series of boot screens before arriving at the main login screen.

Enter default administrative login credentials:

Username:..... admin

Password: admin2

3.7 System Checks

On the **Process** screen, navigate to **Tools>Manual Control** and perform the following system checks for initial validation of the Cee® Apogee® Bake Plate.

Set Lift Pins

Select a **Control** of **Lift Pins** and an **Action** of **Set**. Enter a value into the **Height** field and tap **Apply**. Verify **Lift Pin Height** readings respond to changes on the **System Values** list.

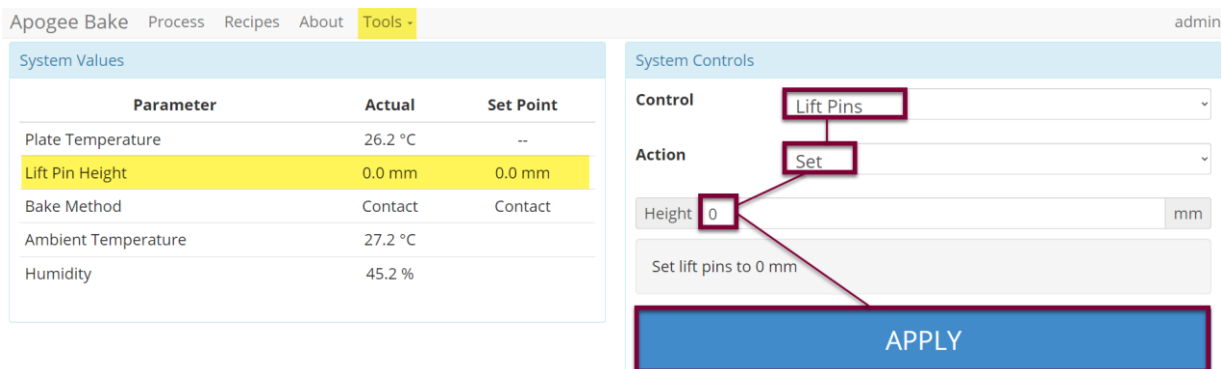

Inset supplied stop pins into the desired holes on the bake plate surface. These stop pins keep the substrate centered on the bake plate surface. Holes closest to center are for 2” substrates. From the center, stop pin locations are for 2”, 3”, 100mm, 125mm, 150mm, and 200mm substrates, respectively.

Bake Methods

Vacuum

Set **Bake Method** to **Vacuum**. Place a substrate on the center of the bake plate and check that the vacuum holds the substrate.

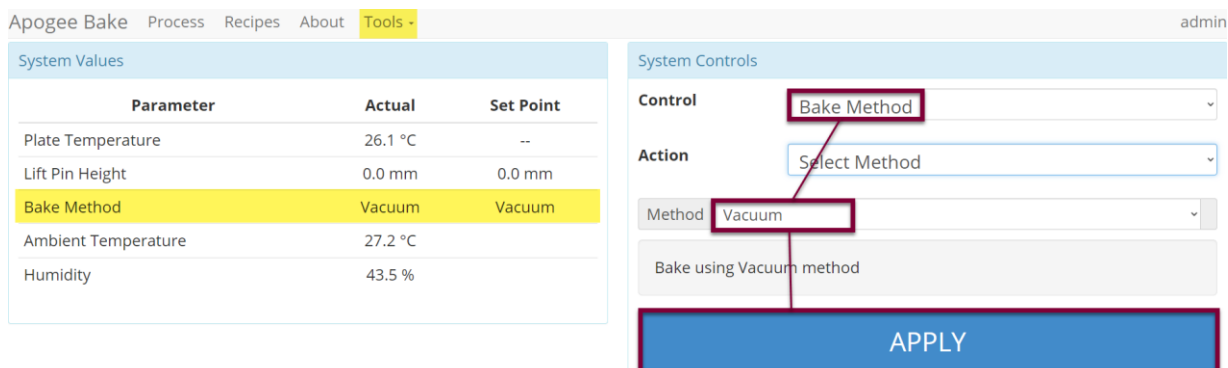

Proximity

Set **Bake Method** to **Proximity**. This will turn off the vacuum and purge N₂ to float the substrate above the bake plate surface.

Apogee Bake Process Recipes About Tools - admin

Parameter	Actual	Set Point
Plate Temperature	26.1 °C	--
Lift Pin Height	0.0 mm	0.0 mm
Bake Method	Proximity	Proximity
Ambient Temperature	27.1 °C	
Humidity	43.0 %	

System Controls

Control: Bake Method

Action: Select Method

Method: Proximity

Bake using Proximity method

APPLY

Contact

Set the **Bake Method** to **Contact**. This will turn off vacuum and N₂. Remove the substrate.

Apogee Bake Process Recipes About Tools - admin

Parameter	Actual	Set Point
Plate Temperature	26.1 °C	--
Lift Pin Height	0.0 mm	0.0 mm
Bake Method	Contact	Contact
Ambient Temperature	27.2 °C	
Humidity	43.3 %	

System Controls

Control: Bake Method

Action: Select Method

Method: Contact

Bake using Contact method

APPLY

Temperature & Humidity Sensor

Ensure the temperature & humidity sensor is functioning by verifying that **Ambient Temperature** and **Humidity** readings are present on the *System Values* List.

Apogee™ Bake Process Recipes About Tools - admin

Parameter	Actual	Set Point
Plate Temperature	24.4 °C	--
Lift Pin Height	19.0 mm	19.0 mm
Bake Method	Contact	Contact
Ambient Temperature	25.2 °C	
Humidity	45.1 %	
Empty Sensor	False	

System Controls

Control: Bake Method

Action: Select Method

Method: Contact

Bake using Contact method

APPLY

Enable & Test Plate Temperature

Use the **Control** drop-down to select **Plate Temperature** then select an **Action** of **Set**, enter the desired plate temperature for your application, and tap **Apply**. *Note that the *System Values* list displays a Set Point of null (--).

Apogee Bake Process Recipes About Tools - admin

System Values

Parameter	Actual	Set Point
Plate Temperature	26.2 °C	--
Lift Pin Height	0.0 mm	0.0 mm
Bake Method	Contact	Contact
Ambient Temperature	27.2 °C	
Humidity	43.4 %	

System Controls

Control: Plate Temperature

Action: Set

Value: 90 °C

Set temperature to 90 °C

APPLY

Change the **Control** selection to **Plate Temperature** then select **Enable** from the **Action** and **Value** dropdowns and tap **Apply**. Note that the temperature entered in the previous step is now displayed as the **Set Point** in the *System Values* list. The **Actual** temperature in the *System Values* list will increase/decrease as the bake surface heats/cool.

Apogee Bake Process Recipes About Tools - admin

System Values

Parameter	Actual	Set Point
Plate Temperature	27.5 °C	90.0 °C
Lift Pin Height	0.0 mm	0.0 mm
Bake Method	Contact	Contact
Ambient Temperature	27.2 °C	
Humidity	43.2 %	

System Controls

Control: Plate Temperature

Action: Enable

Value: Enable

Enable temperature controller

APPLY

Once these operations have been validated, the Cee® Apogee® Bake Plate is ready for use. Begin by creating a recipe. Refer to the [DataStream™ Manual](#) for more information and refer to section 4 of this manual for Bake Plate specific DataStream™ features.

4 DataStream™ Technology

This section covers information specific to the Apogee® Bake Plate and is intended as a companion to the DataStream™ Technology Software Manual. *Please review the DataStream™ Operations Manual* for detailed guidance on software usage.

4.1 System Parameters

Parameter	Actual	Set Point	Status
Plate Temperature	59.4 °C	60.0 °C	In Range
Lift Pin Height	19.0 mm	19.0 mm	In Range
Bake Method	Contact	Contact	In Range
Ambient Temperature	26.5 °C		In Range
Humidity	44.8 %		In Range

Plate Temperature⁴	the current temperature of the hot chuck displayed against the target set point in degrees Celsius
Lift Pin Height	the height of exposed lift pins in relation to the chuck in millimeters; precision control settings range from 0.0-19.0
Bake Method	dictates the manner in which the substrate is heated; vacuum, contact, proximity, lift pins; refer to the Apogee® Bake Plate Operations Manual for more information.
Ambient Temperature	the air temperature of the environment where the equipment is housed
Humidity⁵	the ambient relative humidity in the environment where the equipment is housed

4.2 Manual Controls – Apogee® Bake Plate

The **Manual Control** activity is an advanced feature that allows users to run most operating processes outside of a recipe. This mode is useful for tasks such as prototyping processes, verifying equipment operation, and recovering from aborted processes. To access the activity, navigate to **Tools > Manual Control**. Actual and set point parameter values are displayed on the left. Available controls will be selected from the dropdown menu on the right.

If using remote feature, the user must confirm local presence to execute manual commands. Refer to the [DataStream™ Manual](#) for guidance on the Local Presence feature.

⁴ A process will not wait to achieve desired temperatures before moving onto the next step. Utilize preconditions or manual controls to ensure platen temperatures are in range before a process is initiated.

⁵ Both Ambient Temperature and Humidity are measured via a custom sensor board mounted next to a ventilation inlet inside the tool. If sensor is disconnected, default of -1.1 is displayed.

Apogee Bake Process Recipes About **Tools -** admin

System Values

Parameter	Actual	Set Point
Plate Temperature	24.5 °C	--
Lift Pin Height	19.0 mm	19.0 mm
Bake Method	Contact	Contact
Ambient Temperature	26.7 °C	
Humidity	41.4 %	

System Controls

Control What do you want to control?

What do you want to control?

Plate Temperature

Lift Pins

Bake Method

Please check your values before applying the change.

APPLY

Plate Temperature

System Values

Parameter	Actual	Set Point
Plate Temperature	41.5 °C	--
Lift Pin Height	-1.0 mm	5.0 mm
Bake Method	Contact	Contact
Ambient Temperature	25.1 °C	
Humidity	45.5 %	

System Controls

Control Plate Temperature

Action Set

Value 45 °C

Please check your values before applying the change.

Select a Control of *Plate Temperature*
 Select an Action of *Set*
 Enter the desired value in °C

Click APPLY

The Temperature Controller must be enabled to initiate the heating process. See next step.

System Values

Parameter	Actual	Set Point
Plate Temperature	41.9 °C	45.0 °C
Lift Pin Height	-1.0 mm	5.0 mm
Bake Method	Contact	Contact
Ambient Temperature	25.0 °C	
Humidity	44.4 %	

System Controls

Control Plate Temperature

Action Enable

Value Enable

Enable temperature controller

Select an Action of *Enable*
 Select a Value of *Enable* or *Disable* to activate or deactivate the temperature controller

Click APPLY

Note that the heating process has been initiated and a plate temperature set point has populated on the system values list. When a value of *Disabled* is selected, a Set Point of - - is displayed and the heating process is terminated.

System Controls

Control

Action

Select an Action of *AutoTune*

Click APPLY

User must first define the set point and enable temperature controller.

Useful for refining the temperature control for a given setting – note that this may take a significant amount of time.

System Controls

Control

Action

Target °C

Rate °C / Minute

Select an Action of *Ramp*

Enter the Target temperature

Enter the desired ramp Rate⁶ (between 1-6°C per minute)

Click APPLY

Lift Pins

⁶ Cee® does not offer active cooling on bake plates however, the ramp feature can be used to reduce the rate of cooling beyond what ambient conditions allow.

System Values		
Parameter	Actual	Set Point
Plate Temperature	42.9 °C	45.0 °C
Lift Pin Height	10.0 mm	10.0 mm
Bake Method	Contact	Contact
Ambient Temperature	25.0 °C	
Humidity	44.7 %	

System Controls

Control Lift Pins

Action Set

Height 10 mm

Set lift pins to 10 mm

Select a Control of *Lift Pins*
 Select an Action of *Set*
 Enter the target height (between 0-19mm)

Click APPLY

Note that the lift pin height set point has populated on the system values list.

System Controls

Control Lift Pins

Action Go Home

Select an Action of *Go Home*

Click APPLY

Lift pins recede beneath the surface of the hot plate until they contact the homing flag for recalibration of position.

System Controls

Control Lift Pins

Action Step

Step Size 19 mm

Direction Up

Select an Action of *Step*
 Enter the desired Step Size (between 0-19mm)
 Select the preferred Direction

Click APPLY

System Controls

Control

Action

Select an Action of *Raise Lift Pins*

Click APPLY

Set pins to the Lift Pin Idle Position specified in section **Error! Reference source not found. Error! Reference source not found.** Review the [Apogee® Bake Plate Operations Manual](#) for more information.

System Controls

Control

Action

Select an Action of *Lower Lift Pins*

Click APPLY

Lift pins recede just beneath the surface of the hot plate to facilitate contact with the substrate.

System Controls

Control

Action

Target mm

Rate mm/min

Select an Action of *Ramp*

Enter the Target (between 0-19mm)

Select the preferred ramp Rate (between 0-200mm/min)

Click APPLY

Bake Method

System Values			System Controls	
Parameter	Actual	Set Point	Control	Action
Plate Temperature	45.3 °C	45.0 °C	Bake Method	Select Method
Lift Pin Height	10.0 mm	10.0 mm	Method	Contact
Bake Method	Contact	Contact	Bake using Contact method	
Ambient Temperature	25.1 °C			
Humidity	44.7 %			

Select a Control of Bake Method
 Select the desired Method (Vacuum, Proximity, or Contact)

Click APPLY

Review the [Apogee® Bake Plate Operations Manual](#) for more information on Bake Methods.

4.3 Preparation

Users with sufficient privileges can **Prepare** equipment to run a recipe. This feature is useful for preconditions and parameters that take a significant amount of time such as hot chuck and platen temperatures. To initiate this feature, navigate to the **Recipes** tab, click **Load** to access the recipes list and select the desired recipe, then click **Prepare**.

Apogee Bake Process **Recipes** About Tools - admin

Recipe Controls

Viewing Recipe- Test_Red_Recipe

Name Test_Red_Recipe Notes

Plate Temperature 180 °C

Step	Time (seconds)	Process Method	Pin Height (mm)
1	60	Contact	

Buttons: Load, Prepare, Run, New

***Preparation processes cannot be initiated when the equipment is already in use.**

Local Display – When a **Prepare** command is entered, the user or device with active control of the machine receives an alert. This prompt includes the user and recipe to be prepared. The user with control of the machine can refuse the request by selecting **Abort** or accept the request by tapping **OK**.

In the absence of a response, the request is auto accepted after two minutes.

User (admin) attempting to set temperature for recipe:

Test_Red_Recipe

Press OK to continue or ABORT to cancel.

OK

00:00:01

Recipe Preparation **Abort**



Preparation In Progress – progress toward the specified precondition(s) is displayed to the user with verified local presence.

Apogee Bake **Process** Recipes About Tools - admin

 **Plate Temperature(130.0 °C) - Within -5% and +5% of 180 °C**

Waiting on preconditions to be in range for recipe ...

(PREHEAT) - Test_Red_Recipe

 Elapsed 00:00:18 **ABORT** Remaining 00:00:00 

Preparation Complete – indicates that the equipment has reached all specified preconditions and the recipe can be initiated. Upon clicking **OK** the user is directed to the *Process* screen to begin the recipe.

Test_Red_Recipe

Ready to run!

OK

00:00:02

Recipe Preparation

**During recipe preparation the Prepare and Run commands are disabled to ensure no interruption to precondition processes.*

4.4 Running Recipes

1. Select Recipe Page

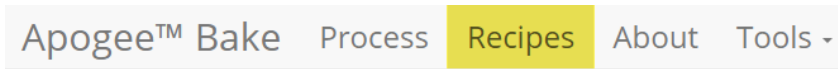

2. Load Recipe

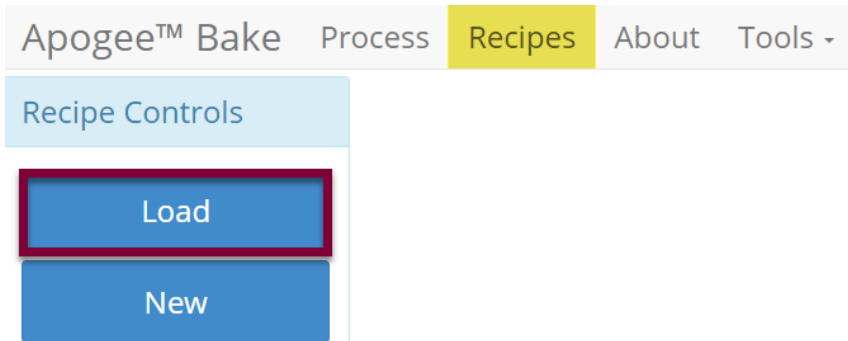

3. Search For, Identify, & Select Recipe

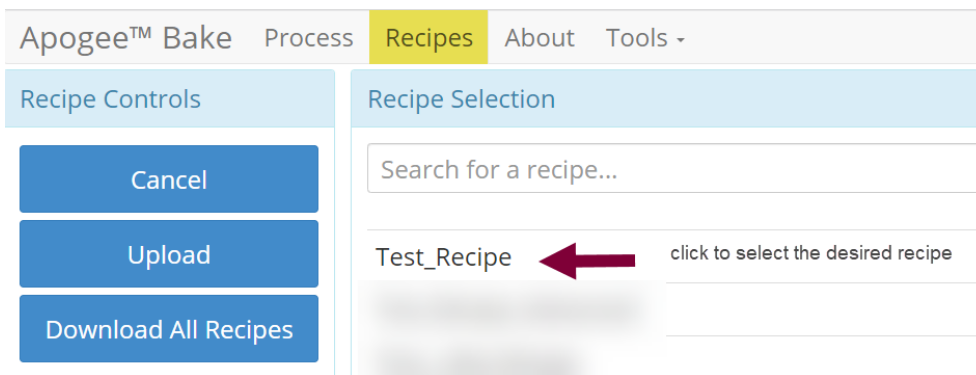

4. Run Recipe

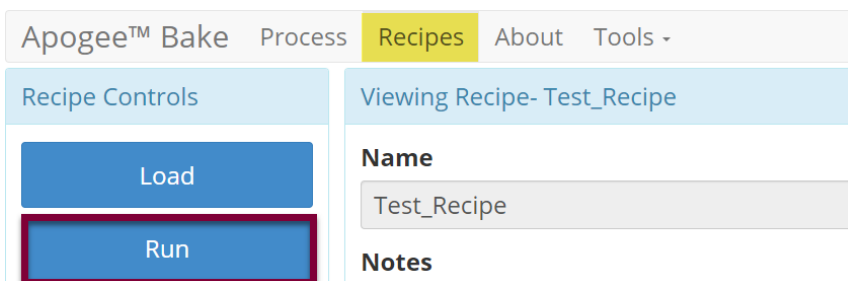

5. Start Recipe

6. Recipe Progression

*Users may be required to follow prompts on the screen during recipe execution.

4.5 Editing Recipes

Step	Time (seconds)	Process Method	Pin Height (mm)
1	60	Contact	
2	30	Contact	
3	30	Contact	
4	60	Proximity	

4.6 Tool Specific Settings – Apogee® Bake Plate

Temperature Offset Calibration (°C)

Offset used by the temperature controller to calibrate the reported chuck temperature

Lift Pin Idle Position (mm)

User defined height of lift pins upon machine start-up and after recipe completion *default value 19mm

Lift Pin Offset (mm)⁷

Offset is supplied for calibration of lift pin positioning.

⁷ Offset impacts all lift pins.

5 Bake Plate Theory

Hotplate bake processing has increased in popularity since the early 1980s. Previously the most common technique for film drying and curing was the convection oven. Bake plates, also known as hotplates, offer several advantages in the form of increased throughput, increased uniformity and reproducibility, and decreased particle contamination. In a typical bake process, the substrate quickly rises to temperature. Drying and curing steps generally take about one minute. This contrasts with traditional oven processes which generally take thirty minutes or more.

5.1 Bake Plates vs Conventional Ovens

Bake plates have several advantages over conventional ovens.

- decreased bake time
- increased reproducibility
- better film quality

This section will describe these differences and set a few guidelines for using bake plates.

Stratification, the formation of different temperature zones, is a problem associated with convection ovens and can severely affect film quality and reproducibility.

The heating rate of a substrate in an oven depends not only on the heated air flow past a substrate but also on its proximity to other cold substrates. Thus, the heating rate for each substrate in a cassette of substrates that are being baked will be less than if each substrate is baked alone.

In addition, substrates near the ends of a cassette heat faster than the substrates in the middle, producing non-uniform heating.

Particle generation also occurs within a standard oven. In a forced-air convection oven, substrates are commonly exposed to a flow of particle laden air for at least thirty minutes.

During resin film cures, the substrates will be exposed to considerable particulate contamination. The substrates are vulnerable since the film may still contain solvents and during this *soft* state the film is very susceptible to having particle adhere to it.

5.2 The Skin Effect

Another disadvantage of normal oven baking results from baking substrates from the *outside in*. Since heat is applied to the outer surface of the film first, a skin forms on the surface of the film, trapping solvents. Upon vaporizing, these solvents form blisters or bubbles which results in adhesion loss or even bulk film failure. This problem prevails in processes involving thick film resins, e.g., polyimides.

No skin effect occurs on a hotplate since hotplate baking heats the substrate from the bottom up. This *inside out* approach offers advantages for thick films since solvents in the film nearest the substrate are baked off before the film surface seals over.

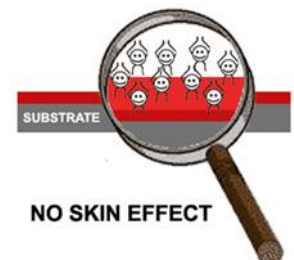
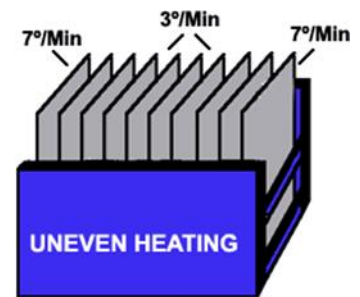
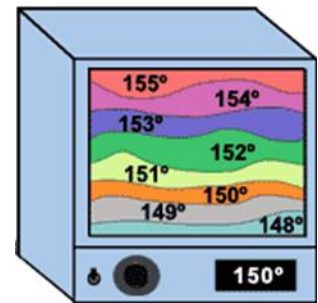

5.3 Hotplate Bake Variables and Methods

A typical bake process consists of preheating the surface to a known temperature, loading the substrate onto the surface for a specific length of time and removing it promptly at the end of the cycle. The selection of the temperature and time values used as well as the bake method employed all affect the overall performance of the process.

5.4 Bake Temperature

The bake temperature used is dependent on several factors. The material and substrate being baked as well as the results desired are key factors to be considered in developing a bake process

In general, hotplate baking will be performed at temperatures slightly higher than those used in oven bake processes. The film being baked will reach a temperature somewhere between the temperature of the hotplate and the ambient air above the film. As an example, with a hotplate surface temperature of 115°C, a layer of photoresist on a silicon wafer will reach a final temperature of about 105°C after a few seconds. Thicker substrates and/or substrates with lower coefficients of thermal conductivity will require even higher temperatures to compensate for this phenomenon.

5.5 Bake Methods

Another important factor is the method of bake. Cee® hotplates allow for three distinct bake methods:

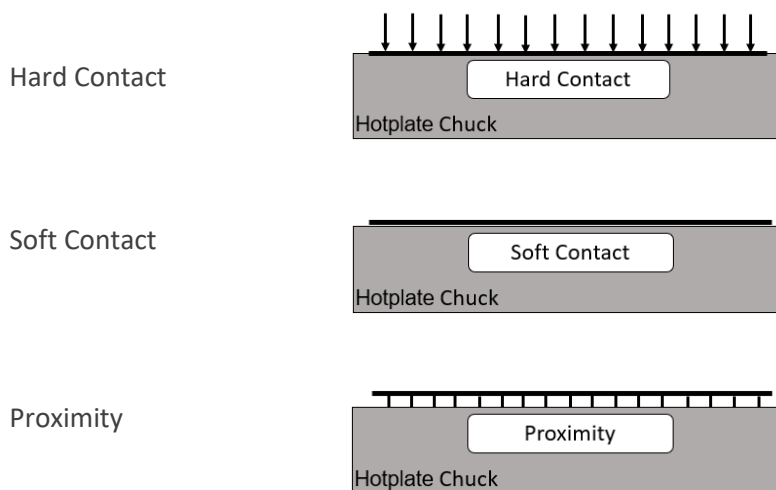

In a hard contact bake, the substrate is held onto the hotplate surface by the application of vacuum to the underside of the substrate. Small holes are machined into the hotplate surface in a pattern which optimizes vacuum distribution without the formation of cold spots or warping of the substrate. This method is usually preferred for silicon and other flat substrates where backside contact is not a problem.

Soft contact baking uses gravity alone to hold the substrate to the hotplate. This method generally offers less uniformity since the substrate-hotplate thermal interface is not as efficient.

Proximity baking is accomplished by forcing nitrogen through ports in the hotplate surface. This forces the substrate to float at a distance of one to four millimeters (25-100µm) above the hotplate surface. Proximity baking allows for a slower warm-up than contact bake methods and can be advantageous when baking thick films where blistering would otherwise be a problem.

Another advantage of proximity baking is that often, cambered, or warped substrates can be baked with a high degree of uniformity. This is usually not possible with the contact methods since it is not possible to achieve a vacuum under a substrate that is not flat to start with. Processing cambered substrates with the soft contact

method creates hot spots where the substrate touches the hotplate and cold spots where it does not. It should be noted as well that this type of proximity process is *self-leveling* in that substrate will tend to form a uniform gap to the hotplate surface.

Proximity baking also offers the unique advantage of allowing hotplate processing without touching the bottom side of the substrate. An example of this application is photomask processing. In processing these relatively thick glass plates it is important that the backside of the glass not directly touch the hotplate since rapid heating will cause micro-fractures in the glass. By performing the entire bake process in proximity mode, the integrity of the substrate is not endangered, and the uniformity is excellent.

5.6 Bake Time

The selection of the bake time parameter plays an important role in the reproducibility of the bake process. Substrate thermal properties and the choice of bake method greatly affect the amount of time necessary for the substrate, and therefore film temperature, to stabilize during the bake. Thicker substrates and the use of proximity bake methods will increase the time necessary for the film to reach its final temperature. It is important that most of the baking action in the film take place after this temperature is reached. A silicon wafer will reach a stable temperature within a few seconds and so it is traditional to adjust photoresist bake processes to be completed in 60-90 seconds with an appropriate bake temperature.

For thicker substrates such as photomask and ceramic modules, the increased time necessary to heat the larger mass of the substrate results in bake times approaching five minutes. It should be noted that these substrates can be processed with higher temperature and shorter bake times, but reproducibility may suffer. If the bake time is too short, a significant amount of the actual bake process will take place during the loading and unloading steps as well as while the substrate is cooling after removal from the bake plate. This is an unstable condition since it is very difficult to exactly reproduce conditions during these steps.

In general, the temperature-time relationship in a bake process can be taken as a dose of the (temperature) x (time) product. Increasing the bake temperature results in a need for decreasing bake time. The limits for both parameters can be reached when the process is no longer reproducible or when the physical temperature limitations of the resin or substrate have been reached.

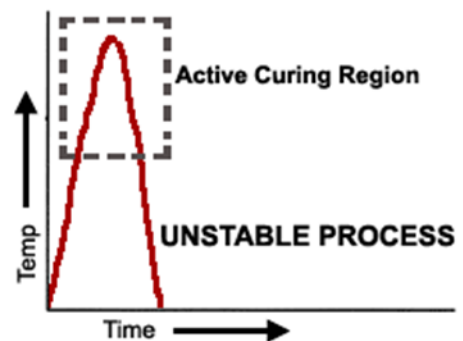
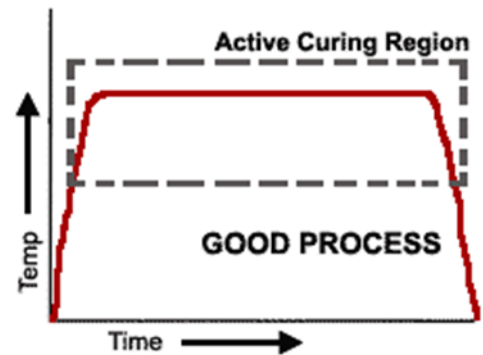

5.7 Exhaust Cover

The design of the Cee® exhaust cover promotes dissipation of vapors removed from a substrate placed on the chuck, without drawing air across the chuck surface.

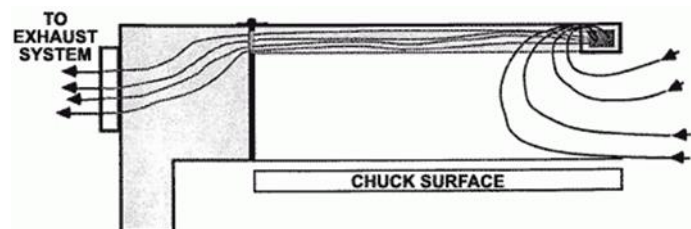

5.8 Oven vs Bake Plate Examples

The chart below presents process examples for commonly used resins. These figures should *not* be used as a rigid guideline since the best method with a particular baking application can only be achieved through experimentation.

Application

Positive Photo Resist

Oven Bake

90°C, 30 minutes, Polyimide beta (partial imidization)

135°C, 30 minutes, Polyimide alpha (solvent removal)

Hotplate Bake

115°C, 30 seconds, hard contact bake, Polyimide beta (partial imidization)

150°C, 15 seconds, proximity bake, 150°C-90 seconds, hard contact bake, Polyimide alpha (solvent removal)

5.9 Reflow Soldering

Bake plate processing heats the substrate and the solder without applying heat directly to the devices on the board. Using a combination of proximity and hard-contact bakes, the bake profile can be adjusted to suit any process.

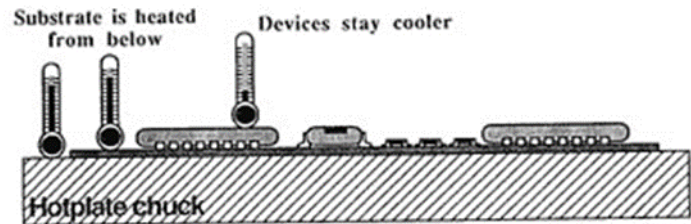

5.10 Bake Plate Process Troubleshooting

As with spin coating process, there are no absolute rules for bake plate processing, only general guidelines. The following is a list of issues to consider for specific bake plate process problems.

Film overbaked

bake temperature too high.....reduce temperature

bake time too long.....decrease bake time

Film underbaked

bake temperature too low.....increase temperature

bake time too shortincrease bake time

Film blistering or cracking

unstable balance in temp/time parameters.....decrease temp/increase time

warm-up time too fast.....use proximity bake to preheat substrate

Non-uniform bake

unstable balance in temp/time parameters.....decrease temp/increase time

operating with exhaust lid raisedlower the exhaust lid

unstable ambient conditionsprotect against major fluctuations

bake time too shortincrease bake time

bake plate surface contaminatedclean surface of bake plate

6 Preventative Maintenance

This section provides personnel with procedures and guidelines for maintaining a Cee® Apogee® Bake Plate.

6.1 Service and Repairs

Safety Notice: Important Repair Information for Cee® Equipment



In order to maintain safety and performance standards, only authorized representatives of Cee® are permitted to conduct repairs or alterations on Cee® equipment.



When servicing the machine, use only replacement parts made or recommended by Cee®.



Use only Cee® supplied shielded cables with this machine.



Unauthorized repairs may lead to serious risks such as equipment malfunction, damage, personal injury, or even death.

6.2 Fault Condition

In the event of a fault condition, power cycle the tool to restore function.

6.3 Safety Checks

Inspect bake plate lid for the following defects:

- loose assemblies
- improper closure
- improper exhaust connection

6.4 Mechanical/Utilities Checklist

<u>Evaluate</u>	<u>Frequency</u>	<u>Detail</u>
Utility Gasses & Vacuum	Daily	Check all gas pressures and vacuum for ranges specified in tool manual.
Exhaust	Daily	Verify that the exhaust is functional with adequate flow.
Bake Plate Surface	Weekly	Buildup of material on the bake plate can cause vacuum errors. For minor build-up wipe the bake surface clean with isopropyl alcohol or acetone. For major build-up of material, utilize a glass slide held at a 45° angle to <i>gently</i> scrape the material away then wipe clean with isopropyl alcohol or acetone.

Lift Pin Height	Quarterly	If the three lift pins are not lifting the wafer programmed amount of distance from the bake plate surface, they may require calibration. See section 4.6 for details.
Power	Bi-Annually	Verify that AC power is connected and of the proper voltage.

6.5 Cleaning

The Apogee® Bake Plate should be cleaned following daily use and only after the equipment has cooled to a safe thermal condition. The cabinet should be cleaned with isopropyl alcohol. When cleaning the hot plate surface, it is good practice to use the mildest solvent possible such as acetone or isopropyl alcohol. **Do not use caustic acids or bases.** For major build-up of material, utilize a glass slide held at a 45° angle to gently scrape the material away then wipe clean with isopropyl alcohol or acetone. Please visit the Cee® YouTube Channel for a [demonstration](#). If these methods are unsuccessful contact [Cee® Customer Support](#) for additional guidance.

Use only water-based cleaner on the labels on the rear of the machine. Use only isopropyl or water-based cleaner on the Power, Cee® logo, Caution ... Eye Protection, and the Cee® model/serial number labels. The display may be cleaned with glass cleaner, water, or isopropyl alcohol.

7 Table of Revisions

Doc Rev #	Author	Description of Change(s)	Reviewed/Approved By	Date
2.4	J. Adams	<ul style="list-style-type: none"> - Updated Section 3.4 Unpackaging & Inspection with Type III hard coat information. 	B. Waterworth	12/9/2024
2.3	J. Adams	<ul style="list-style-type: none"> - Added Section 2.6 NRTL 	B. Waterworth	7/11/2024
2.2	J. Adams	<ul style="list-style-type: none"> - Added French translations to all warnings throughout the manual. - Updated Section 1.3 Returned Materials to Include Cee® Physical Address - Updated Section 1.9 Thermal with appropriate warning symbol. - Updated Section 1.10 Chemical with appropriate warning symbol. - Updated voltage ratings to Sections 0 - Utilities and 3.2 Facilities Requirements 	B. Waterworth	6/03/2024
2.1	J. Adams	<ul style="list-style-type: none"> - Update Apogee™ to Apogee® - Amended section 1.12 Intended Use of Machine - Amended section 2.1 User Controls - Amended section 0 - Utilities - Amended section 3.2 Facilities Requirements - Amended section 3.4 Unpackaging & Inspection - Added section 6.1 Service and Repairs - Added section 6.2 Fault Condition 	B. Waterworth	8/30/2023

2.0	J. Adams	<ul style="list-style-type: none">- update format- add section 3.1, Clearance Requirements- add section 4, DataStream™ Technology- add section 7, Table of Revisions	B. Waterworth J. Strothmann	11/09/2022
-----	----------	---	--------------------------------	------------